

**JDN OPERATION AND ASSEMBLY  
INSTRUCTIONS AIR HOISTS**

**PROFI 3 TI, PROFi 6 TI, PROFi 10 TI, PROFi 16 TI,  
PROFi 20 TI**

**MONORAIL HOISTS**

**EH 10, EH 16, EH 20**

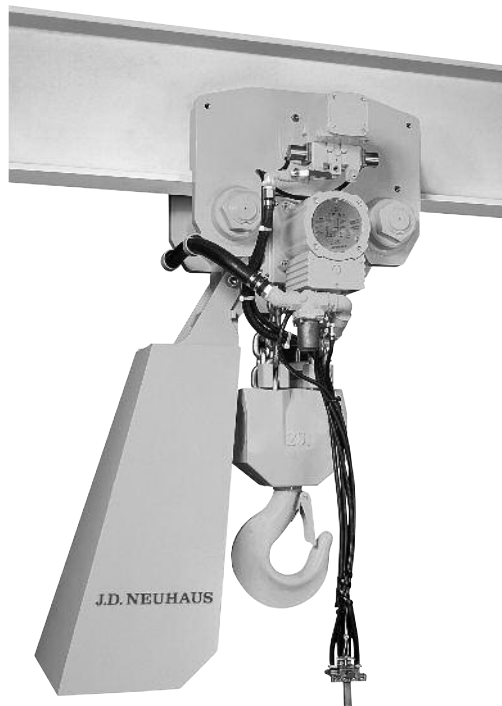

Original Operation and  
Assembly Instructions

**J·D·NEUHAUS**  
1745

Please enter the Fabr. No. of your JDN Air Hoist here.

This operation manual edition 07/2012, covers the following JDN Air Hoists:

### **PROFI 3 Ti**

Fabr. No.

### **PROFI 6 Ti**

Fabr. No.

### **PROFI 10 Ti**

Fabr. No.

### **PROFI 16 Ti**

Fabr. No.

### **PROFI 20 Ti**

Fabr. No.

and the following JDN Monorail Hoists (EH), only in conjunction with the operation manual **JDN Trolleys**:

### **EH 10**

Fabr. No.

### **EH 16**

Fabr. No.

### **EH 20**

Fabr. No.

It must be read carefully and in its entirety before operating any air hoist. For hoists installed in trolleys, please also refer to the operation manual **JDN Trolleys**.

# TABLE OF CONTENTS

## SAFETY MEASURES

Organisational measures	5
Personnel safety	5
Preventing property damage	5

## PRODUCT INFORMATION

The operation manual	6
Warnings and symbols	6
Labelling	7
Assembly overview	8
Product description	8
Explosion protection	9
Intended use	15
Emissions	15
Operating conditions	15
Energy requirements	17
Principle of operation of JDN air vane motors	18
Operation without chain box	19
Motor lubrication / operation with service unit	19
CE marking / declaration of incorporation	19
Spare parts	19

## TRANSPORT AND STORAGE

Safe transportation	20
Storage conditions	20

## INITIAL OPERATION

Unpacking	21
Assembly	21
Installing the hoist	21
Connecting the controls	22
Replacing controls	25
Connecting to the main air supply	27
Lubricants	27
Checking prior to initial operation	28

## OPERATION

Rules for safe operation of hoists	29
Controls	32
Emergency stop device	34
Overload protection	34
Attaching the load	34
Lifting the load	35

Lowering the load	35
Detaching the load	35
Interrupting working	35

## TAKING OUT OF OPERATION

Shutting down	36
Storage	36
Dismantling	36
Disposal	36

## MAINTENANCE

Maintenance and inspection intervals	37
Cleaning and care	37
Spare parts	37
Lubricants	37
Inspection and repairs	37
Instructions concerning the "model for determining the actual operating time"	39
Lubricate the chain	43
Checking braking function	43
Checking lifting and lowering limiters	43
Checking controls and emergency stop function	44
Checking the main air emergency-stop valve	44
Checking direction of movement	44
Checking the silencer for permeability	44
Service unit	45
Replacing brake disc, brake piston and vanes /motor installation/motor lubrication	48
Removing and installing load sleeve, bottom block, clamp and buffer	50
Checking chain, chain sprocket and chain guides	54
Check dimension	55
Checking axial play	56
Removing and installing chain	57
Replacing chain and chain sprocket	58
Overload protection	59

## FAULTS, CAUSE AND REMEDY

Fault table	61
-------------	----

## ACCESSORIES

Filter silencer	62
Booster unit	62
Chain box	63

## APPENDIX

Technical data	64, 66
Dimensions	65, 67
Air flow sheets	68

**Please note:**

**Within the Federal Republic of Germany** operators of air hoists must comply with trade association accident prevention regulations and rules, as well as state occupational safety regulations, in particular

- ▶ BGV A1 accident prevention regulations "Principles of Prevention"
- ▶ BGV D8 accident prevention regulations "Winches, Lifting and Pulling Devices"
- ▶ BGR 258 trade association regulations "Operation of Load-Carrying Devices Used with Lifting Equipment"

and, for air hoists installed in trolleys and for the operation of monorail hoists, additionally with

- ▶ BGV D6 "Accident Prevention Regulations for Cranes"

in the respective currently applicable version. Operators must also initiate the prescribed tests (see also "Principles for the Testing of Cranes" BGG 905 (ZH 1/27)).

To document the tests we recommend the "Inspection log for cranes" BGG 943 (ZH 1/29) from the trade association.

When operating air hoists in areas with explosive atmospheres, the operator must comply with the relevant explosion protection regulations, e.g.

- ▶ BGR 104 "Explosion Protection Regulations" and
- ▶ BGR 132 "Prevention of Ignition Hazards due to Electrostatic Charges"

**In all other countries**, the operator shall comply with local regulations as applicable.

Special regulations may apply when incorporating air hoists into other installations or using air hoists under unusual conditions.

## SAFETY INSTRUCTIONS

### ORGANISATIONAL MEASURES

JDN Hoists are designed in accordance with current technological standards and accepted safety practice. Nonetheless, the use of an air hoist may be associated with risk of injury or fatality to the user or to third parties or with the risk of damage to the hoist or to other items, if safety rules are disregarded.

All personnel charged with operating air hoists, must have read and understood the operation manual, especially the section entitled "Rules for the safe operation of hoists", before commencing work. This is particularly important for personnel who only occasionally operate the hoist, e.g. for maintenance or retrofitting work.

Operators of JDN Hoists are also under obligation to ensure safe and hazard-free operation. This can be achieved through the following measures:

- ▶ keeping the operation manual available at the hoist's operating site at all times
- ▶ performing regular training,
- ▶ perform regular inspections (at least once annually),
- ▶ implement an inspection log and make regular entries,
- ▶ and regularly check personnel for safety and hazard awareness during work.

### PERSONNEL SAFETY

Personnel who operate, maintain, inspect and perform setting-up work on the hoist must be properly trained or must receive an introduction from properly trained personnel, before commencing work.

Due to their technical training and experience, properly trained personnel have adequate knowledge of hoists. They are sufficiently familiar with the relevant occupational safety and accident prevention regulations, that they are able to assess the condition of hoists, with regard to working safety.

- ▶ Follow the operating instructions for your workplace.
- ▶ Comply with the accident prevention regulations.
- ▶ Ensure that you are properly informed regarding working with hazardous materials.
- ▶ Follow the safety instructions set out in the operation manuals.

### PREVENTING PROPERTY DAMAGE

Operators of JDN Hoists are under obligation to ensure that entries in the accompanying inspection log are made properly and regularly.

- ▶ Comply with the prescribed maintenance intervals.
- ▶ Only use JDN Hoists for work which is described as intended use.
- ▶ Observe the operating conditions for JDN Hoists as described in this manual.

## PRODUCT INFORMATION

### THE OPERATION MANUAL

This operation manual is intended to help the operator familiarise himself with JDN Air Hoists and to take full advantage of their designated areas of application.

This operation manual contains important information for the safe, proper and efficient operation of JDN Air Hoists. Observance of the manual helps to avoid hazardous situations, to reduce repair costs and downtimes and to ensure the specified service life of the JDN Air Hoists.

### WARNINGS AND SYMBOLS

Safety warnings in this operation manual are classified in three categories.



#### **DANGER!**

Safety warnings, which if not followed can result in hazard to life and limb, are indicated by this symbol. The symbol indicates an immediate danger. The possible consequences of non-observance may be severe or even fatal injuries.



#### **CAUTION!**

This symbol indicates potentially hazardous situations. Failure to observe may result in light injuries.



#### **ATTENTION!**

This symbol indicates that failure to follow the relevant instructions may result in damage to the device or other equipment.

**LABELLING**

The nameplate mounted on the housing cover identifies the type of JDN Air Hoist and contains all important rating data.

If you have any questions concerning operation of JDN Air Hoists, which are not addressed in this operation manual, please contact us at the following address:

J.D. NEUHAUS GMBH & CO. KG  
 Windenstraße 2-4  
 D - 58455 Witten-Heven

Phone +49 2302 208-0  
 Fax +49 2302 208-286  
 www.jdngroup.com  
 e-mail: info@jdngroup.com

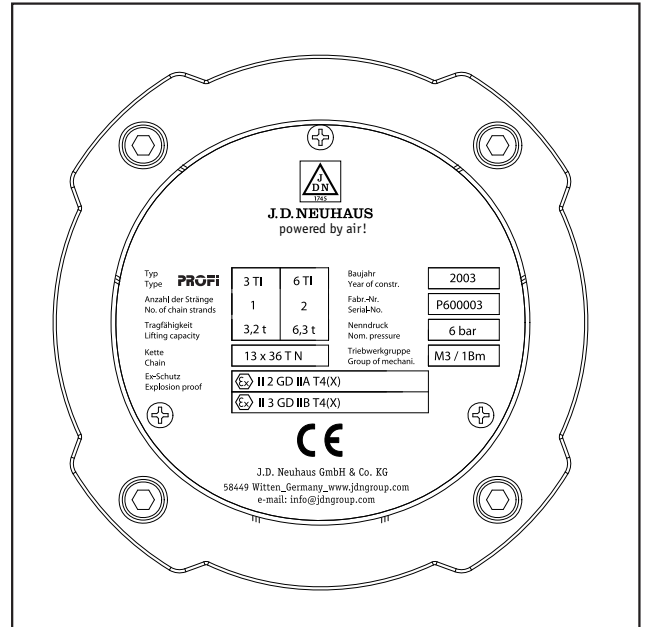

Example of nameplate on housing cover

**ASSEMBLY OVERVIEW**

PROFI TI air hoists and **monorail hoists** consist of the following assemblies:

- 1 Gearbox with chain sprocket and overload protection
- 2 Centre section
- 3 Motor with integral brake function
- 4 Controls with main air EMERGENCY STOP
- 5 Chain
- 6 Load hook with load sleeve or bottom block and buffer

**PRODUCT DESCRIPTION**

The PROFI TI series JDN Air Hoists and EHs described here are designed for load-carrying capacities from 3.2 t (PROFI 3TI ) to 20 t (PROFI 20TI/EH 20).

Various control devices are available for the different requirements.

The air vane motor of the hoist, together with the appropriate controls, is capable of sensitive movement. This enables precise positioning of the load.

PROFI TI JDN Air Hoist and EH motors feature rotors with grease chambers. These contain JDN highperformance grease which enables operation with oilfree compressed air. It remains effective for an operating period of approx. 250 hours and should be renewed when required, but after five years at the latest (see **Motor lubrication**, page 19). Additional lubrication with oil-bearing compressed air by means of a service unit with oiler is possible.

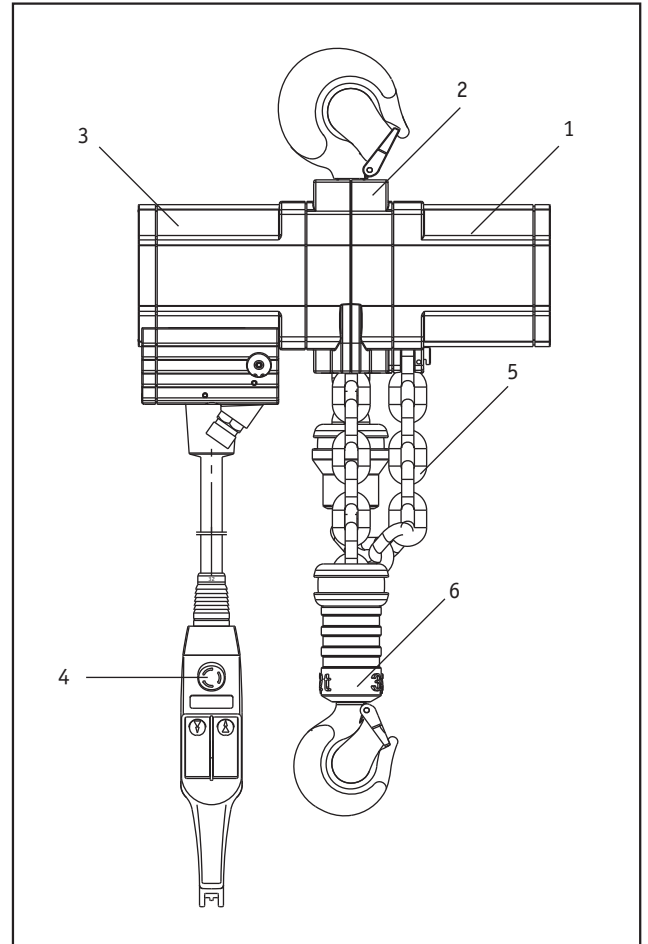

PROFI TI series JDN Air Hoists

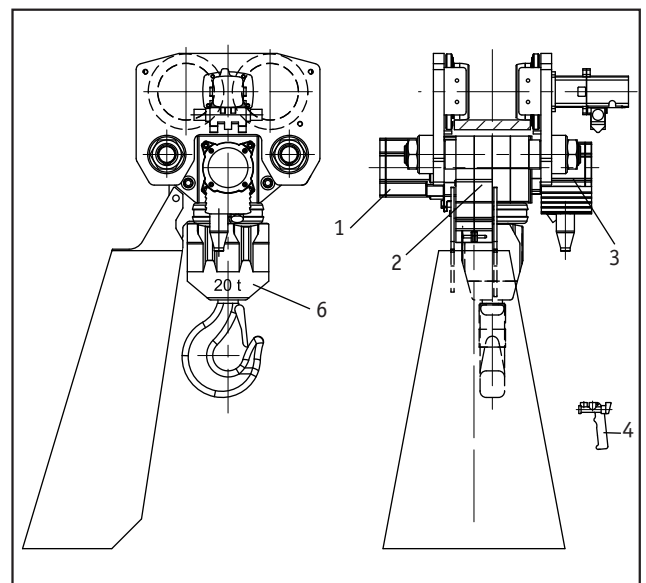

JDN monorail hoists EH



## EXPLOSION PROTECTION

The basis for the following information is an expert statement by the DMT Gas & Fire Division on the use of JDN Hoists, Trolleys and Crane Systems in explosion-hazardous areas, based upon European Guideline 94/9/EC<sup>1</sup> ("ATEX 100a"). DMT is accredited with the testing of devices and protection systems for intended use in explosion-hazardous areas.

### BASIC EXPLOSION PROTECTION FOR THE STANDARD VERSIONS (EXCLUDING MINI)

Standard version JDN Air Hoists are category 2 devices (Guideline 94/9/EC, DIN EN 1127-1<sup>2</sup>), for use in zone 1 and 2 for gases of explosion group IIA. (See also IEC 60079-12<sup>3</sup> and IEC 60079-20<sup>4</sup>). These devices are also suitable for use in zone 2, in the presence of gases of explosion group IIB, provided that the substances hydrogen sulphide and ethylene oxide can be excluded and additionally in zones 21 and 22 for dusts with glow temperatures above 210° C or ignition temperatures above 202° C, provided that no light metal or other impact-sensitive dusts are present.

These devices are designated by:

**⊕ II 2 GD IIA T4(X) / II 3 GD IIB T4(X)**

Additional marking "X", see page 10.

### JDN HOISTS "WITH INCREASED SPARK PROTECTION"

JDN Hoists in the "with increased spark protection" version (SP), fulfil further explosion protection requirements. With the exception of carbon disulphide (temperature class T6), they can be used in the presence of all gases in zones 1 and 2 and dusts with glow temperatures above 210° C or ignition temperatures above 202° C in zones 21 and 22, and can be designated with **⊕ II 2 GD IIC T4(X)** for installation in a trolley, depending upon trolley version (see below), but also with **⊕ II 2 GD IIB T4(X)**. For further operating conditions, see Instructions for safe operation (Notes **D** and **E**).

### JDN HOISTS FOR USE IN THE PRESENCE OF TEMPERATURE CLASS T6 GASES OR EXTREMELY EXPLOSIVE DUSTS

Following separate tests, especially with regard to ambient temperatures and type of operation, use in the presence of carbon disulphide or dusts with particularly low glow or ignition temperatures may be possible with designation **⊕ II 2 GD IIC T6(X)**, which includes the Additional marking "X" for special conditions (see Additional marking "X"). Please contact us with regard to these requirements.

### STANDARD JDN TROLLEY AND CRANE RUNNING GEAR

JDN Trolleys and Cranes can be used in zone 2 with standard running wheels (made of steel or cast metal) with all dusts and the presence of gases up to explosion group IIC. Due to the low running speeds, the possible friction velocities on the running wheels are less than

1 m/s, so that standard running wheels can also be used in zone 1 up to explosion group IIB. The highest possible designation for these devices is:

**⊕ II 2 GD IIB T4(X) / II 3 GD IIC T4(X)**.

Depending on the hoist version, designations

**⊕ II 2 GD IIA T4(X) / II 3 GD IIB T4(X)** or

**⊕ II 2 GD IIB T4(X)** are also used.

### JDN TROLLEY AND CRANE RUNNING GEAR "WITH INCREASED SPARK PROTECTION"

For use in zone 1 in the presence of gases in explosion group IIC, bronzed running wheels or running wheels made of bronze will also be used. The highest possible designation for this version (FSR) will be

**⊕ II 2 GD IIC T4(X)** (the same as for JDN Hoists "with increased spark protection").

### JDN TROLLEY AND CRANE RUNNING GEAR FOR USE IN THE PRESENCE OF TEMPERATURE CLASS T6 GASES OR DUSTS

As is the case with JDN Hoists "with increased spark protection", temperature class T6 could also be possible in this case too in the event of a special investigation of applicability, so that the highest possible designation for standard wheels and for bronzed or bronze wheels are **⊕ II 2 GD IIB T6(X) / II 3 GD IIC T6(X)** and **⊕ II 2 GD IIC T6(X)** respectively, i.e. each including the additional designation "X" for special conditions.

### GENERAL NOTE ON DESIGNATION

The highest possible respective designations for lifting equipment and running gear are usually replaced by a designation, which corresponds to the normal assembly of a compact complete device (trolley or crane system).

### ADDITIONAL MARKING "X"

This designation refers to explosion protection details in the operation manual.

⊕ II 2 GD IIA T4(X)/ II 3 GD IIB T4(X) or

⊕ II 3 GD IIA T4(X):

This designation does not permit use in the presence of the extremely flammable substances hydrogen sulphide and ethylene oxide or in the presence of light metal or other impact-sensitive dusts, or in the presence of dusts with glow temperatures below 210° C or ignition temperatures below 202° C. The permissible ambient temperature range (Ta) extends from - 20° C to + 70° C.

⊕ II 2 GD IIC T4(X) or ⊕ II 2 GD IIB T4(X):

The permissible ambient temperature range (Ta) extends from - 20° C to + 70° C.

⊕ ...IIC T6(X):

This designation permits use in the presence of carbon disulphide or other temperature class T6 substances only under special conditions, which have been agreed with the manufacturer and which are described in the crane documentation and which stipulate the maximum surface temperatures for the device.

### USAGE IN MINING APPLICATIONS

Standard versions of JDN Hoists, Trolleys and Crane Systems may generally also be used for underground mining operations as well as for the associated surface facilities, which are hazardous due to firedamp and/or combustible dusts. Within this equipment group I they belong to category M2. The devices must be switched off in the event of an explosive atmosphere being formed. They are equipped with protective measures offering a high degree of safety. The protective measures with which products of this category are equipped provide the necessary degree of safety for normal operation as well as operation under difficult conditions, in particular rough treatment and changing environmental influences. For other difficult conditions in addition to explosion protection prevailing with regard to the general handling of the devices in mining applications, special mining hoists are available from

J.D. NEUHAUS. The maximum permissible temperature of 150° C in accordance with EN 13463-1<sup>5</sup> for coal dust atmospheres is not reached. For mining applications, the relevant designation for hoists, trolleys and crane systems is ⊕ I M2.

### LOAD CHAIN

In order to guarantee the required degree of earthing, extremely rusty chains must no longer be used in zones 1 and 21 or in category M2 devices. As, depending upon the degree of corrosion, the leakage capability of the chain may be impaired to a level that is no longer adequate.

### COMPRESSED AIR HOSES

In zone 1, compressed air hoses must have a sufficiently low surface resistance of less than 10<sup>9</sup> Ω, in order to prevent electrostatic ignition hazards. Otherwise (resistance >10<sup>9</sup> Ω), for explosion groups I, IIA and IIB the hoses must be Ø ≤ 30 mm and for explosion group IIC Ø ≤ 20 mm, or proof must be provided that they cannot become dangerously charged.

### MATERIALS FOR FRICTION AND IMPACT HAZARDS

Friction and impacts can give rise to individual sparks presenting a danger of ignition in the presence of explosion group IIC gases, hydrogen sulphide, ethylene oxide, or light-metal or other impact-sensitive dusts. Accordingly, spark formation caused by mechanical influences must be prevented. The chain and load must always be moved in such a way that sliding and/or frictional contact with other plants or components is excluded. If circumstances do not permit this, it is necessary to ensure an absence of explosive atmospheres during operation.

Impacts between particular materials result in an increased ignition hazard. This does not apply to corrosion-resistant steel or cast iron against aluminium, magnesium or corresponding alloys. This applies especially in the presence of rust or rust film. Rust (also rust film) formation is possible, especially on the chain and on the load hook, at the friction points. The following holds true for all zones: For the intended use of hoists it must be ensured that no rust is present at the above-mentioned friction points and that material combinations of the above-named light metals with steel (exception being stainless steel) or cast iron are not used in the working area of the hoists, at potential

friction, impact or sliding points. It is thus possible to exclude sparking due to mechanical influences with these material combinations.

The external housing of the service units is made of aluminium. Therefore the installation position is to be selected so as to ensure that there is no risk from impact sparks.

### **EARTHING**

Electrostatic ignition hazards can be prevented by means of safe earthing. In zones 1 and 21, earthing of the hoists is required. This must be achieved via the load hook or the load eyes, if the lifting equipment is connected to correspondingly earthed parts (earth leakage resistance less than  $10^6 \Omega$ ). This also applies to operation with trolleys or cranes. Their tracks must be earthed on site. Running wheels and rail surfaces must never be painted, as this can result in unacceptably high earth leakage resistance values.

Earthing of the load hook is via the chain (see also **Load chain**, page 10).

Loads must be earthed during transportation. A separate earth is required, for example, when using non-conducting sling gear.

### **CLEANING PLASTIC SURFACES**

Where JDN Air Hoists or JDN Air Winches feature plastic parts, these surfaces must only be cleaned using a damp cloth (cleaning cloth with water). This reduces electrostatic charging that can arise due to mechanical friction at the plastic surface.



#### **DANGER!**

Electrostatic charging may occur at the plastic surfaces, potentially leading to electrostatic discharge that can ignite gases and air mixtures.

### **ACETYLENE AND COPPER**

When operating JDN products in explosion-hazardous areas, in which an acetylene-containing atmosphere can occur, it must be ensured that copper-plated parts are kept dry, in order to exclude the possibility of oxidation of the metallic copper and the formation of a aqueous phase, which is capable of reacting with acetylene and which can result in an explosion hazard.

**EXPLOSION GROUPS AND TEMPERATURE CLASSES OF THE MOST IMPORTANT GASES AND VAPOURS (-SELECTION-)**

(in accordance with DIN VDE 0165<sup>6</sup>, Redeker<sup>7</sup>, Nabert, Schön<sup>8</sup>, IEC 60079-12<sup>3</sup> and IEC 60079-20<sup>4</sup>)

Ex group	Temperature class					
	T1	T2	T3	T4	T5	T6
	Ignition temperature					
	> 450° C	450-300° C	300-200° C	200-135° C	135-100° C	100-85° C
Maximum permissible surface temperature of operating facilities						
	450° C	300° C	200° C	135° C	100° C	85° C
<b>II A</b>	Acetone Ammonia Aniline Benzol Chlorobenzene 1,2-Dichlorobenzene Acetic acid Ethane Ethyl acetate (Ethyl bromide) Ethyl chloride (Carbon monoxide) o-Cresol Methane Methyl acetate Methyl alcohol*1 Methyl bromide Methyl chloride Methylene chloride Naphthalene (nitrobenzene) Phenol Propane Toluene o-Xylene	(Ethyl alcohol) (Ethylene glycol) i-Amyl acetate n-Butane n-Butyl alcohol 1-Butylene 1,2-Dichloroethane Di-i-Propyl ether Natural gas Acetic anhydride n-Propyl acetate (n-Propyl alcohol) i-Propyl alcohol Vinyl chloride	n-Amyl alcohol Benzene (petrol) Diesel Fuel oil n-Hexane jet fuels	Acetaldehyde		
<b>II B</b>	Hydrocyanic acid (Ethyl bromide) (carbon monoxide) (Nitrobenzene) Town gas	Butadiene-1,3 Dioxane-1,4 Divinyl ether (Ethyl alcohol) Ethylene (ethylene glycol) **Ethylene oxide Isoprene (n-Propyl alcohol)	Dimethylether **Hydrogen sulfide	Ethyl ether Ether Anaesthetic ether Diethyl ether		
<b>II C</b>	**Hydrogen	**Acetylene				**Carbon disulphide

( ): The measured values for the substances placed in brackets are close to the limit or the next group or class when classified in the explosion groups or temperature classes. For this reason, they have been included in both.

\*\* : Extremely flammable substances (cf. additional marking "X")

\*1 (Methanol = Methyl alcohol)

**DECISION CRITERIA FOR SELECTING THE CORRECT JDN HOISTS  
IN EXPLOSION-HAZARDOUS AREAS**

Explosion groups of gases and vapours (See Explosion groups and temperature classes of the most important gases and vapours)	Zone	Version*1 Manufacturer's responsibility			Operation*2 Operator's responsibility		
		A	FS	FSR	D	E	T
II A	2	A				E	
	1	A				E	
II B (X) except hydrogen sulphide, ethylene oxide (particularly flammable)	2	A				E	
	1	A	FS			E	
II B	2	A	FS		D	E	
	1	A	FS		D	E	
II C / T4	2	A	FS		D	E	
	1	A	FS	FSR	D	E	
II C / T6(X)	2	A	FS		D	E	T
	1	A	FS	FSR	D	E	T
Explosion-hazardous dusts	Zone	Version*1			Operation*2		
Usual industrial dusts	22	A				E	
	21	A				E	
Light-metal or impact-sensitive dusts	22	A	FS		D	E	
	21	A	FS		D	E	

**\*1: Version features (under the responsibility of the manufacturer):**

A: The chain is made of zinc-plated steel; metal controls are conductively connected to the hoist. This is part of the standard equipment. For technological reasons, a zinc-plated version of chain size 31.5 x 90 is not available. This is only used for the extremely slow-running chain drives of large hoists, so that the sliding velocity for potential friction points between the chain and the surroundings remains well below 1 m/s.

SP: Hoists "with increased spark protection":

Copper-plated load hook and bottom block with brass safety catch.

FSR: Running gear "with increased spark protection":

Running wheels for trolleys and cranes are made of bronze.

**\*2: Instructions for safe operation (operator's responsibility):**

**D** : Ignition hazards are not to be expected if hoists or cranes are used in the normal manner. Friction and impacts in the working area of the chain, not resulting from intended use of the hoist or crane and which result in sparking, must be excluded, or an absence of gas in the operating area must be ensured. This means, for example, that the chain, the bottom block and the load hook must be prevented from swinging against surrounding objects or that a gas-free environment must be ensured.

**E** : Friction, impact and sliding points involving combinations of light metal and steel or cast iron must not be present in the hoist's operating area.

**T** : Ambient temperature and the type of operation must be examined separately.

**TEMPERATURE LIMITS FOR EXPLOSION-HAZARDOUS DUSTS**

In areas which are explosion-hazardous due to combustible dusts, the surface temperature must not exceed two-thirds of the ignition temperature in °C of the dust/air mixture. The temperatures of surfaces on which hazardous deposits of combustible dusts can be formed, must not exceed the glow temperature of the relevant dust minus 75K. Greater safety margins are required if the thickness of the dust layer exceeds 5 mm.

The corresponding surface temperatures can be derived from the lowest values for glow and ignition temperatures of dusts specified in the HVBG/BIA Report 12/97<sup>10</sup> "Combustion and explosion characteristics of dusts":

Synthetic rubber, soot-containing:  
Glow temperature  $220^{\circ}\text{C} - 75^{\circ}\text{C} = 145^{\circ}\text{C}$  max.  
permissible surface temperature

Stearic acid:  
Ignition temperature  $190^{\circ}\text{C} \times 2/3 = 126^{\circ}\text{C}$  max.  
permissible surface temperature

**PLEASE ALSO OBSERVE YOUR CORRESPONDING NATIONAL REGULATIONS.**

- <sup>1</sup> Guideline 94/9/EC of the European Parliament and the Council dated 23rd March 1994 on the adaptation of the laws of the Member States concerning equipment and protective systems intended for use in potentially explosive atmospheres
- <sup>2</sup> DIN EN 1127-1: Explosive atmospheres - Explosion prevention and protection - Part 1: Basic concepts and methodology, 1997-10
- <sup>3</sup> IEC 60079-12: Electrical apparatus for explosive gas atmospheres, Part 12: Classification of mixtures of gases and vapours with air according to their maximum experimental safe gaps and minimum igniting currents, 1978
- <sup>4</sup> IEC 60079-20: Electrical apparatus for explosive gas atmospheres, Part 20: Data for flammable gases and vapours relating to the use of electric apparatus, 1996-10
- <sup>5</sup> EN 13463-1: Non-electrical devices intended for use in explosive areas - part 1: Basic methodology and requirements, 07/2009
- <sup>6</sup> DIN VDE 0165: Installation of electrical systems in areas with explosion hazard, 1991
- <sup>7</sup> Redeker, Schön: 6. Supplement to safety-related characteristic values for flammable gases and vapours, 1990
- <sup>8</sup> Nabert, Schön: Safety-related characteristic values for flammable gases and vapours, 2nd edition, 1978
- <sup>9</sup> DIN EN 50014 (VDE 0170/0171 part 1): 2000-02  
Electrical apparatus for use in explosion hazardous areas: General provisions
- <sup>10</sup> HVBG/BIA report 12/97: Central association of German employer's liability associations/trade association institute for industrial safety

## INTENDED USE

JDN Air Hoists are designed for lifting and lowering loads within the specified load-carrying capacities, with a vertically-arranged chain. JDN Air Hoists from the ranges PROFI 3 TI to 20 TI are also suited to pulling loads horizontally. Please also observe the individual national regulations. In combination with trolleys, JDN Air Hoists are also suitable for the floorless horizontal movement of loads.

Any other use or use outside these stipulations is deemed to be impermissible. Oblique pulling, see **Operation** section, page 29. J.D. NEUHAUS GMBH & CO. KG cannot be held liable for any resulting damage. The entire risk is borne by the user (see also **Rules for safe operation of hoists**, page 29).

Intended use also includes observance of the operation manuals and compliance with the inspection and maintenance conditions.

## EMISSIONS

The noise emission data can be found in the **Technical data** table, pages 64 and 66.

The noise pressure level of the measurement area at a distance of 1 m from the machine surface was measured in accordance with DIN 45 635, Part 20, at the operating air pressure specified by us. In the hall, the noise pressure level drops by approx. 3 dB (A) every time the distance is doubled.

If the device is operated with motor oil lubrication, small amounts of lubrication oil will be released into the environment with the outlet air.

Oil emissions can be prevented by using a filter silencer (see **Filter silencer** section, page 62). This also results in a reduction of the noise emission values.

## OPERATING CONDITIONS

JDN Air Hoists are extremely robust and require little maintenance. They are suitable for use in explosion-hazardous areas, as well as in areas with increased concentrations of soot and dust, high humidity and at ambient temperatures of -20° C up to approx. +70° C if they are not heated above this level due to external influences. The thermal endurance of chains and hooks is +150° C.



### CAUTION!

When touching metallic hand controls which are colder than 0° C, the skin could freeze within a few seconds, and for temperatures above 43° C, burns can occur. As a protective measure, please wear suitable gloves.

For stationary outdoor operation, hoists must be protected against weathering and the maintenance intervals must be shortened.

Depending upon the version, JDN Air Hoists must be operated at a system pressure of 4 bar or 6 bar (see information on the nameplate). If the system pressure is too low, important functions of the hoist will be impaired:

- ▶ The brake will drag and is thus subject to a high degree of wear. An impermissibly high degree of warming could take place.
- ▶ The controls become noticeably less sensitive.



### DANGER!

#### Warning against excessive system

**pressures** Operating with excessive system pressures results in danger due to overloading. Therefore, the pressure must be limited to that specified on the nameplate.

JDN Air Hoists must be operated with a sufficiently clean and dry air supply. The air supply must fulfil the following quality requirements:

- ▶ Particle size less than 40 µm
- ▶ Particle density less than 10 mg/m<sup>3</sup>  
(corresponds to Class 7 in accordance with ISO 8573-1:2001)

In order to provide adequate compressed air quality, operation with a service unit is recommended. Usually, an oiler is not required in the service unit, as the motor is provided with internal permanent lubrication.

- ▶ Pressure dew point at least 10° C below the lowest expected ambient temperature.

### **Do not operate JDN Air Hoists with other gases!**

With moist air and ambient temperatures at or below 0° C, there is a danger of icing in the motor.

Icing can be prevented by:

- ▶ the use of an upstream air dryer or using a service unit with oiler,
- ▶ adding anti-icing agent to the lubrication oil (depending upon moisture content of compressed air)
- ▶ or using compressed air oil (Art. no. 11900) with anti-icing agent for relevant temperatures.

In the event that your JDN Air Hoist is operated in combination with a trolley, please also read the trolley operation manual and the relevant accident prevention regulations for operation with trolleys.



**ENERGY REQUIREMENTS**

For air pressure, air quantity and connections, see the **Technical data** table in the hoist operation manual concerned.

**AIR PRESSURE CONDITIONS IN OPERATION**

The system pressure in the air line must correspond to the nominal pressure. Higher pressures must be reduced.

After switching on, the nominal pressure  $p_1$  drops to the actual pressure  $p_2$ .

The value of the actual pressure  $p_2$  at which the hoist is operated, depends upon

- ▶ the weight of the load and
- ▶ the direction of movement of the load.

When lifting the nominal load (load-carrying capacity), the actual pressure  $p_2$  must not fall below a value of 10% below the specified nominal pressure of the hoist.

**Example:**

A hoist with a nominal pressure of 6 bar lifts its nominal load at the specified lifting speed, at an actual pressure of 5.4 bar.

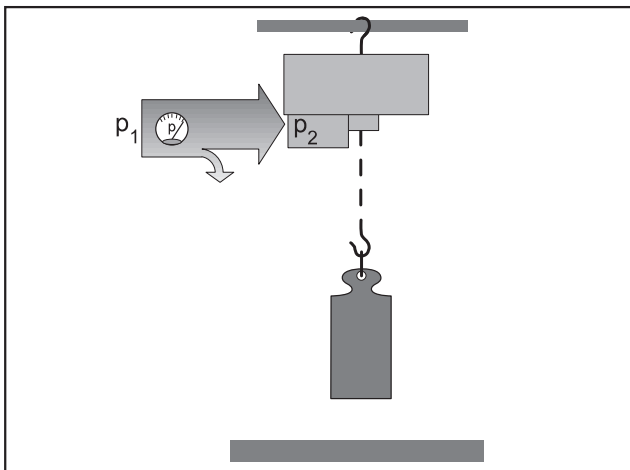

*The value of the actual pressure depends upon ...*

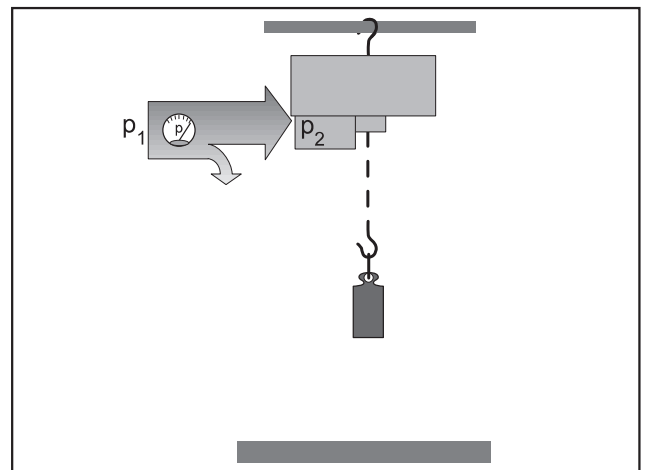

*... the weight of the load ...*

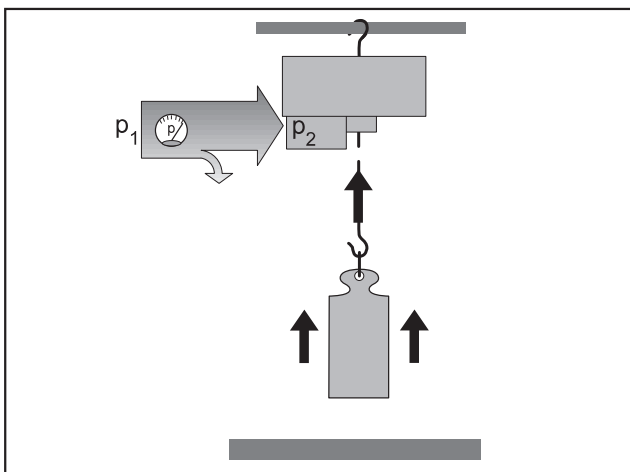

*... and the direction of movement of the load.*

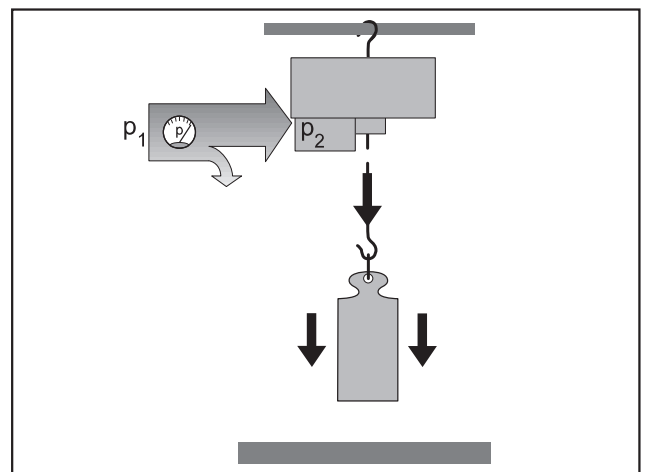

**PRINCIPLE OF OPERATION OF JDN AIR VANE MOTORS**

The vane motor consists of a cylinder liner **1** with two side bearing plates and an internal rotor **2**.

The rotor is mounted eccentrically in the cylinder liner and is provided with slots **3** for installation of the vanes **4**.

The vanes can move freely and make contact with the inner wall **5** of the cylinder liner. Each chamber is formed by two vanes **6**.

Due to the incoming compressed air, a greater force is created at the leading, larger vane surface **4.1** than that at the trailing, smaller vane surface **4.2**. The difference in force generates the rotor torque.

As the chamber passes the outlet aperture **7**, the compressed air can escape.

Lubricant chambers **8** are provided between the vane slots of the rotor. They ensure continual motor lubrication.

The arrows in the illustration indicate the direction of rotation of the rotor and the corresponding path of the compressed air.

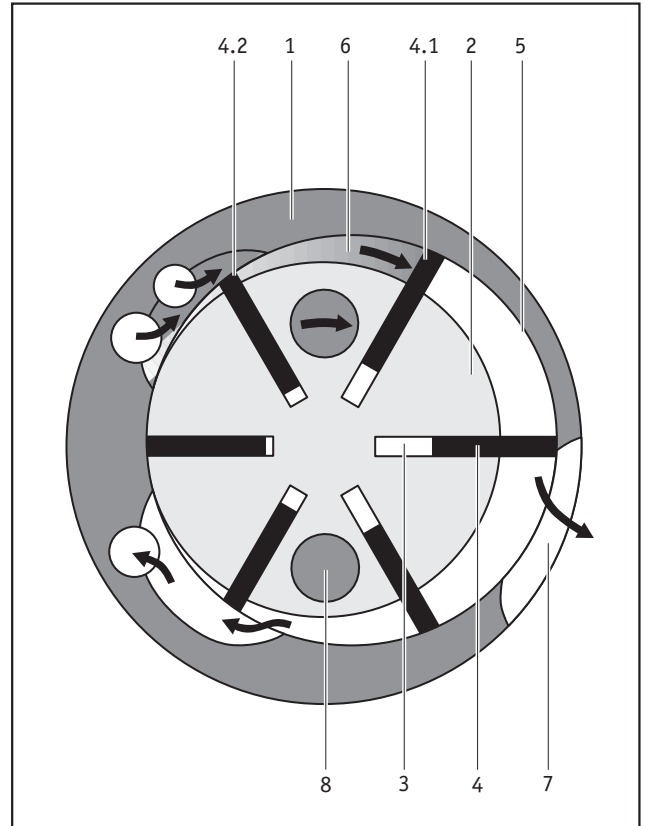

### OPERATION WITHOUT CHAIN BOX



**DANGER!**

If JDN Air Hoists are operated without a chain box it must be ensured that the idle chain (unloaded chain end) running up or down at the chain sprocket, does not present a hazard, e.g. due to catching, impacting or falling.

Danger due to falling chain can also arise, if the idle chain is first deposited on a load with a large surface and then slides off and drops.

### SPARE PARTS

Only use **original JDN spare parts**. J.D. NEUHAUS GMBH & CO. KG accepts no liability for the use of non-original components and/ or modifications by unauthorised persons.

### MOTOR LUBRICATION/ OPERATION WITH A SERVICE UNIT

JDN Air Hoists are provided with motor lubrication which must be renewed when required, but every 5 years at the latest. Therefore, the service unit for filtration and pressure-regulation of the compressed air can be installed without an oiler. If required, the service unit is also available with an oiler. Synthetic lubricants must not be used when operating with a service unit. Alcohols are not permitted for use as anti-icing agents.

### CE MARKING/DECLARATION OF INCORPORATION

Only hoists for which EC conformity in accordance with EC Machinery Directive 2006/42/EC has been declared may be operated within the EU.

In the case of a **CE** designation, only the EC conformity declaration provides information on which EC directive has been met.

## TRANSPORT AND STORAGE

### SAFE TRANSPORTATION

If you wish to transport your JDN Air Hoist to another site, please observe the following points:

- ▶ Carefully dismount trolley (if available).
- ▶ Set the entire hoist down carefully; do not allow it to drop. See **Technical data**, page 64 and 66 for information on weights.
- ▶ Lay control and supply hoses together in such a way that they are not kinked.
- ▶ Please ensure that the controls are not damaged. Could lead to malfunctions.
- ▶ Draw in the hoist's chain in such a way that loops cannot form and the chain cannot become twisted.
- ▶ Secure the chain.

### STORAGE CONDITIONS

#### BREAKS IN OPERATION

- ▶ In the case of longer operational breaks, coat the chain and hook with a light oil film.
- ▶ Motor conservation  
If the motor lubrication is not renewed after the specified intervals, the motor must be conserved. For this purpose, use a non-resinous and non-sticky conserving oil with a conserving protection duration which corresponds to the length of the planned operational break.

#### STORAGE

- ▶ Close off the air supply hose connection using adhesive tape or a suitable cap, in order to prevent dirt ingress.
- ▶ Protect the air supply hose from being damaged.
- ▶ Store your JDN Air Hoist in a clean and dry place.

## INITIAL OPERATION

### UNPACKING



**CAUTION!**

When unpacking, take account of the weight of the hoist. See **Technical data**, page 64 and 66.



**ATTENTION!**

Do not kink the control lines. Kinked control lines can result in malfunctions.

- ▶ Keep the accompanying documents in the place provided, near the operating site.
- ▶ Lift the hoist carefully out of the packaging.
- ▶ Dispose of packaging in the local recycling system.

### ASSEMBLY

JDN Air Hoists are usually delivered pre-assembled.

If not, first read the following sections:

- ▶ **Connecting the controls**, page 22
- ▶ **Removing and installing chain**, page 57
- ▶ **Chain box**, page 63

In the event that the chain is included unattached, a short auxiliary chain is drawn into the hoist. In order to draw in the chain, the hoist must be connected to the main air supply and must be ready for operation.

**PRIOR TO INITIAL OPERATION, THE CHAIN MUST BE LUBRICATED (SEE LUBRICATING THE CHAIN SECTION, PAGE 43).**

### INSTALLING THE HOIST



**DANGER!**

JDN Air Hoists must only be installed by qualified personnel. Faulty installation can lead to severe accidents.



**DANGER!**

The attachment points for JDN Air Hoists must be able to safely withstand the expected forces.



**DANGER!**

The supporting structure of the air hoist must form a rigid mounting. Vibration damages the chain and can lead to chain fracture. Furthermore, external vibration must on no account be transmitted to the hoist (lifting gear). (e.g. from the suspended load).

- ▶ Provide a suitable working platform.
- ▶ Attach the hoist at the suspension hook (or suspension eye) to the running gear or a stationary fixing.
- ▶ Ensure that the hook safety catch closes automatically.

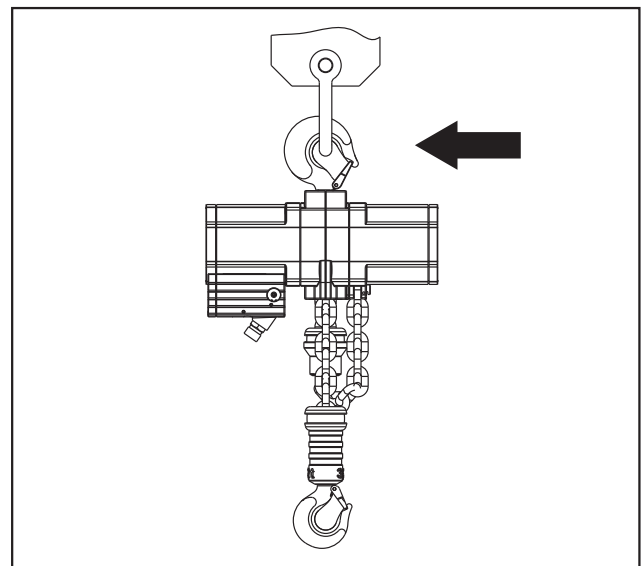

*Attach the hoist securely at the suspension hook or suspension eye.*



**DANGER!**

When loads are taken up suddenly on slack chain, especially using hoists with high lifting speeds, forces are generated which may be equivalent to several times the load weight.

Type	Force
PROFI 3 TI	1.4-times load-carrying capacity
PROFI 6 TI	1.3-times load-carrying capacity
PROFI 10 TI, EH10	1.25-times load-carrying capacity
PROFI 16 TI, EH16	1.2-times load-carrying capacity
PROFI 20 TI, EH20	1.15-times load-carrying capacity

## CONNECTING THE CONTROLS

### CONNECTING THE ROPE CONTROLS

- ▶ Knot both control ropes at the ends of the control lever.
- ▶ Knot the green pin into the rope which activates "lift" mode, with the pointed end upwards (also see **Rope control** illustration, page 34).
- ▶ Knot the yellow pin into the rope which activates "lower" mode, with the pointed end upwards.
- ▶ Knot the handle into the rope so that the arrow markings correspond to the actual direction of movement.

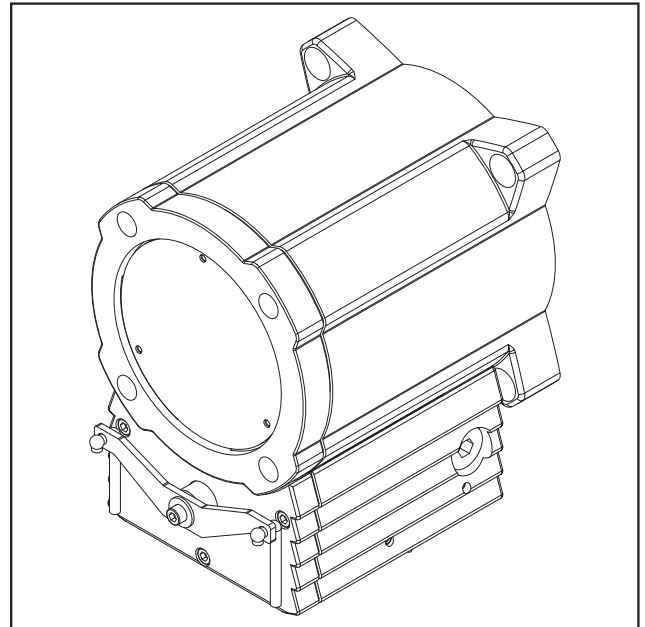

*Rope control, motor side*

### E-CONTROL CONNECTION

#### Pushbutton valve (hand control)

- ▶ Guide the strain-relief cable through the eye on the pushbutton valve and secure using the cable clamp.
- ▶ Push the one-ear clamps onto the hose ends.
- ▶ Attach the hoses to the hose nipples.
- ▶ The one-ear hose clamp must lie in the middle of the hose nipple clamping range. The best clamping characteristics are achieved in this range.

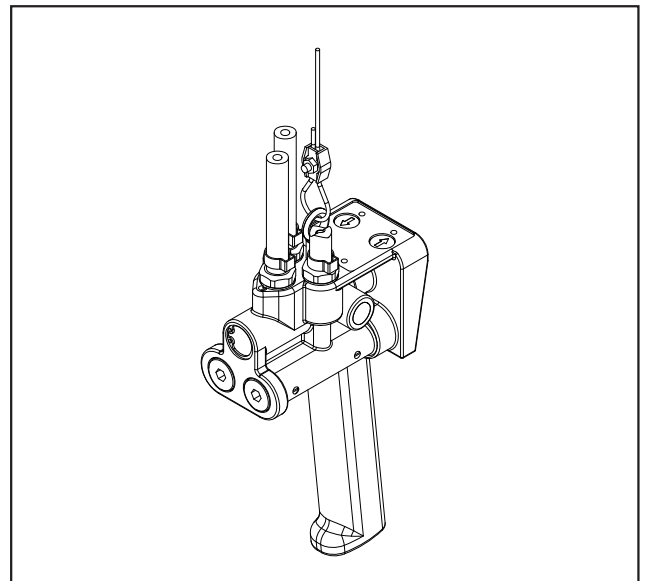

*Pushbutton valve with nipple and rope with designation lift and lower*

- Secure the hoses using the one-ear hose clamps and crimping tool.



**ATTENTION!**

To ensure perfect sealing, the "ear" must be fully closed on installation.

**Installation example**

Position the clamp on the hose with nipple.  
Crimp the clamp ear until fully closed.

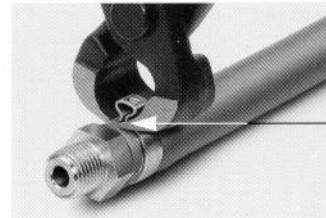

Permissible aperture after crimping

Use of the normal crimping tool ...

*Pinched one-ear clamp and crimping tool*



in order to remove the clamp, set the crimping tool transversely to the clamp ear and cut the ear open ...

*Removal*

- The bellows must be pulled over the other end of the hose bundle including the strain-relief cable (coat hose bundle with oil for ease of fitting). Pull the bellows back far enough to permit further installation. Push the one-ear clamps onto the free ends of the hoses.

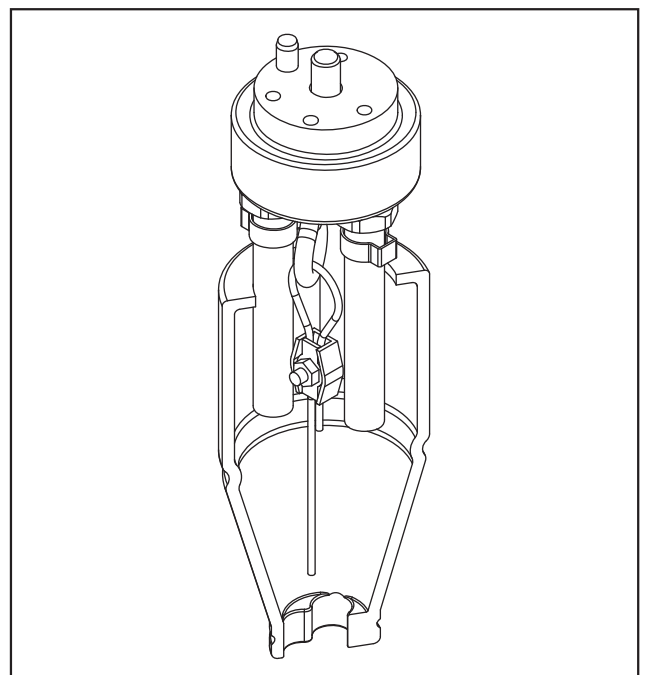

*Illustration of bellows with hoses and strain-relief rope*

**Control valve (on motor)**

Note: In order to connect the hoses to the control valve, we recommend removal of the hose adapter.

- ▶ Remove the hose adapter (secured via central bolt).
- ▶ Attach the hoses to the corresponding nipples (see designation in illustration).
- ▶ Secure the hoses using the one-ear hose clamps and crimping tool.
- ▶ Secure the strain-relief cable.



**ATTENTION!**

The strain-relief rope must be installed with the correct length in order to prevent loading of the hoses.

- ▶ Pull the bellows over the hose adapter. The upper collar of the bellows fits into the recess of the hose adapter.
- ▶ In order to secure the hose adapter to the control valve, a long A/F 6 socket spanner must be guided between the three hoses, through the middle of the bellows and inserted into the hexagon socket of the bolt.

**F-CONTROL CONNECTION**

Pull the bellows over the hose bundle for F-control. For F-control for lifting and lowering only, remove approx. 80 mm of hose bundle protective sheathing; for F-controls with additional functions (trolley/crane movement) remove approx. 160 mm from end of protective sheathing.

Pull the strain-relief ropes through the eye bolt and secure them using rope clamps.

**Insert the control hoses:** See illustration above

Compressed air  
with hose designation 1 or colour: white

Movement direction "lift"  
hose designation 2 or colour: green

Movement direction "lower"  
hose designation 3 or colour: red

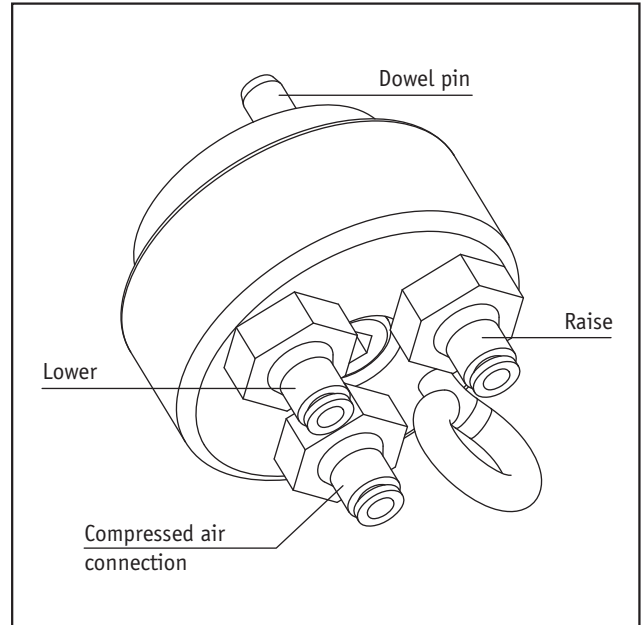

*Hose adapter with nipples designation lift, lower*

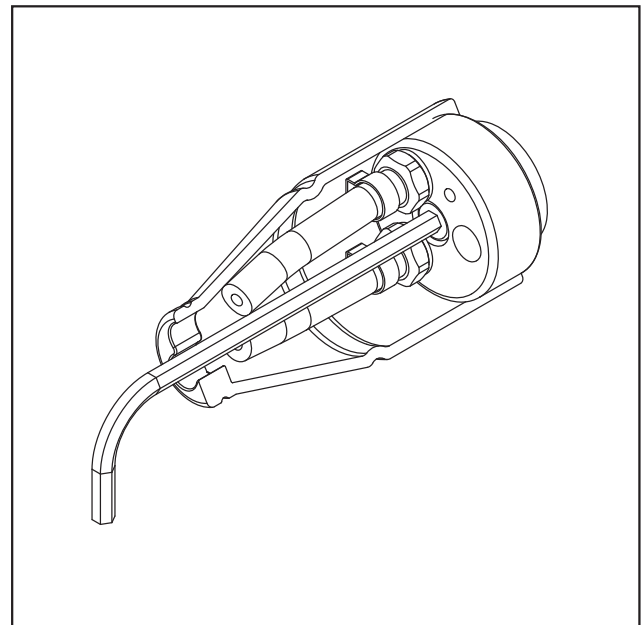

*Bellows with A/F 6 socket spanner*



The control hoses for the drive motors (trolley/crane movement) must be extended, outside of the bellows, by means of plug-in connectors and additional control hoses.

**Connection** see "Trolley" operation manual.



**ATTENTION!**

The control hoses must not be subject to tensile load; adjust the strain-relief cables accordingly.

Pull the bellows over the hose adapter and secure via the central bolt (see illustration on page 24, bottom).

**FI-CONTROL CONNECTION**

Pull the bellows over the hose bundle for F-control. Remove approx. 80 mm of hose bundle protective sheathing.

With this type of control, strain-relief of the hand controls takes place via the protective sleeve of the hose bundle. For this purpose, the protective sleeve is pushed onto the hose carrier and is secured using a one-ear clamp.

**Installation facilitation:** Heat the protective sleeve (hose sheathing) with a hot-air gun and grease the hose carrier.

Slightly bend open the ring of the eye bolt in order to attach the hose carrier. Close the ring again to prevent detaching.

**Insert the control hoses:**

See illustration on page 24, top.

Compressed air  
with hose designation 1 or colour: white

Movement direction "lift"  
hose designation 2 or colour: green

Movement direction "lower"  
hose designation 3 or colour: red



**ATTENTION!**

The control hoses must not be subject to tensile load; adjust the protective sleeve accordingly.

Pull the bellows over the hose adapter and secure via the central bolt (see illustration on page 24, bottom).

**REPLACING CONTROLS**

Conversion to another type of control is a significant modification to a hoist. Following conversion, national safety regulations, including testing regulations, must be observed. If you wish to exchange air controls E, F or FI, proceed as follows (see illustrations in Connecting the controls section)

**CONVERSION FROM E TO F**

Control valve housing (on motor)

**Removal of E-controls**

Remove the hose adapter (secured by central bolt). For removal of the hose adapter, a long A/F 6 socket spanner must be guided through the middle of the bellows and inserted into the hexagon socket of the bolt (illustration on page 24, bottom).

Pull the bellows back over the hose until the hose nipples with the one-ear clamps are exposed and further removal is possible.

Detach the strain-relief rope and remove the one-ear clamps (see **Removal** illustration, page 23).

Cut off the hoses below the hose nipples using a knife. Unscrew the hose nipples (A/F 17).

Pull the bellows over the hoses of the E-controls. This is also required for the F-controls.

**Installation of F-controls**

Pull the bellows over the hose bundle for F-control. Remove approx. 80 mm of the hose bundle protective sheathing or 160 mm for additional movements. Screw the "straight screw connections" (Steckfix) for 4 mm hoses into the hose adapter (A/F 16). Pull the strain-relief ropes through the eye bolt and secure them using rope clamps.

**Insert the control hoses:**

See illustration on page 24, top.

Compressed air  
with hose designation 1 or colour: white

Movement direction "lift"  
hose designation 2 or colour: green

Movement direction "lower"  
hose designation 3 or colour: red



**ATTENTION!**

The control hoses must not be subject to tensile load; adjust the strain-relief cables accordingly.

Pull the bellows over the hose adapter and secure via the central bolt, (see page 24, bottom).

**CONVERSION FROM E TO FI**

Removal of E-controls as previously described (page 25).

**Installation of FI-controls**

Pull the bellows over the hose bundle for FI-control. Re-move approx. 80 mm of hose bundle protective sheathing.

Screw the "straight screw connections" (Steckfix) for 4 mm hoses into the hose adapter (A/F 16).

With this type of control, strain-relief of the hand controls takes place via the protective sleeve of the hose bundle. For this purpose, the protective sleeve is pushed onto the hose carrier and is secured using a one-ear clamp.

**Installation facilitation:** Heat the protective sleeve (hose sheathing) with a hot-air gun and grease the hose carrier.

Slightly bend open the ring of the eye bolt in order to attach the hose carrier. Close the ring again to prevent detaching.

**Insert the control hoses:**

See illustration on page 24, top.

Compressed air with hose designation 1 or colour: white

Movement direction "lift" hose designation 2 or colour: green

Movement direction "lower" hose designation 3 or colour: red



**ATTENTION!**

The control hoses must not be subject to tensile load; adjust the protective sleeve accordingly.

Pull the bellows over the hose adapter and secure via the central bolt (see illustration on page 24, bottom).

**CONVERSION FROM AIR CONTROL TO ROPE CONTROL**



**ATTENTION!**

Only air controls without upstream main-stream valve can be converted to rope control.

**Removal of air controls**

Remove the hose adapter (secured by central bolt). For removal of the hose adapter, a long A/F 6 socket spanner must be guided through the middle of the bellows and inserted into the hexagon socket of the bolt (illustration on page 24, bottom).

The cover "1" in the axis centre must be removed (M 6 bolt, A/F 5).

**Installation of rope controls**

The connecting surface of the hose adapter on the valve housing is closed off with a disc, (from conversion kit Art. no.: 13590, item 10) and is secured with the M 8 x 16 countersunk screw (item 50).

The dowel pin (roll pin, item 70) must be inserted in the bore "2" provided.

Insert the rope control lever connector (item 20) into the cover bore with the lug "3" facing upwards; push on the control lever (item 30) and secure with the M6 x 35 bolt (item 40) and washer (item 60).

Guide the control ropes "4" through the bores "5" in the lever and knot them. Rope colour: "green" lift, "red" lower. Further, see section **Connecting the rope controls**, page 22.

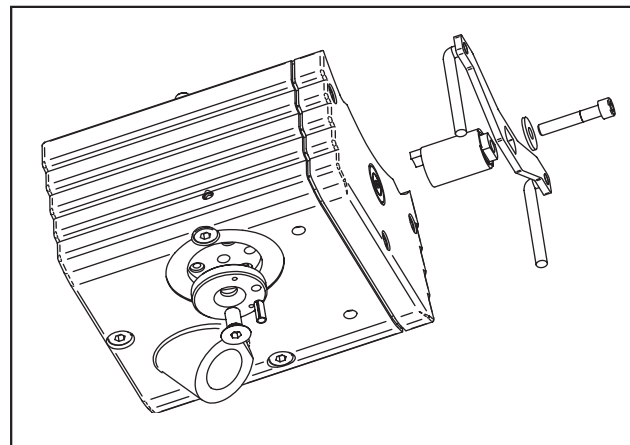

*Installation of rope controls*

### CONNECTING TO THE MAIN AIR SUPPLY

- ▶ Check air connection for contamination and clean if necessary.
- ▶ Blow through compressed air hose in order to remove foreign bodies.
- ▶ Attach the compressed air hose to the connection on the hoist or on the service unit. Tighten the union nut.

### LUBRICANTS

The following lubricants are intended for normal environmental influences.

In the case of wear-promoting environmental influences, please contact J.D. NEUHAUS, to receive the appropriate instructions.



#### CAUTION!

Oils and greases can cause skin irritation. Wear protective gloves.



#### ATTENTION!

Potential damage! Do not mix synthetic oils or greases with mineral oils, as the properties may be impaired.

Also, never mix different types of lubricating grease within the synthetic or mineral lubricant groups.

Synthetic lubricants must not be used when operating with oilers.

Alcohols are not permitted for use as anti-icing agents.

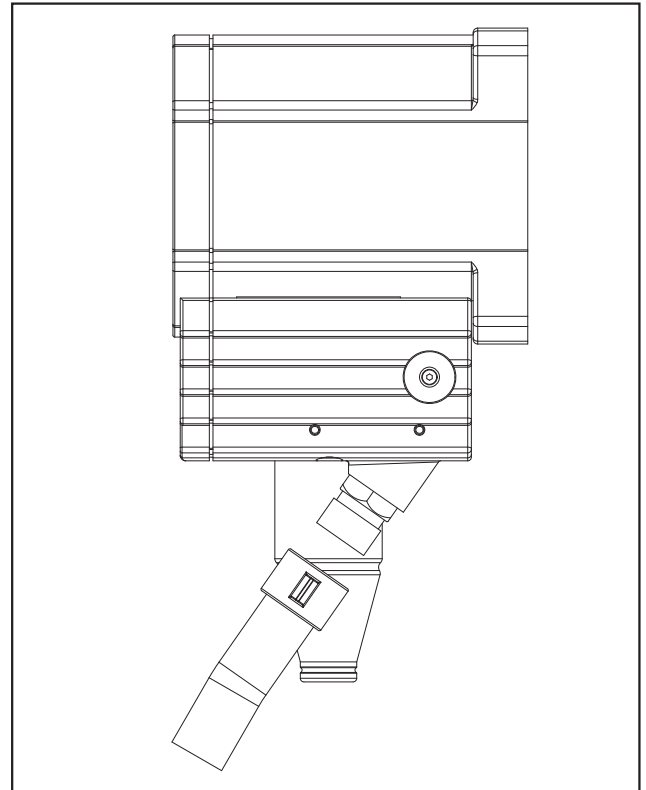

*Attach the compressed air hose and tighten the union nut.*

Application	Lubricant
Motor lubrication - from factory - when operating with oiler	- JDN high-performance grease, Art. No. 11901 (250 ml) - Compressed air oil D, kinematic viscosity approx. 30 mm <sup>2</sup> /s (cSt) at 40° C, with anti-icing agent where applicable
Chain lubrication	chain oil or motor vehicle engine oil, kinematic viscosity approx. 150 mm <sup>2</sup> /s (cSt) at 40° C, or special lubricant from J.D. NEUHAUS In areas with very high corrosion potential, e.g. offshore, a lubricant with extremely strong anti-corrosion properties must be used.
Motor conservation (not applicable when using JDN high-performance grease)	Non resinous Conservation oil with appropriate period of effectiveness
Motor cleaning (not applicable when using JDN high-performance grease)	Pure petroleum
Lubrication of bearings and gearbox (also for exposed gears)	Lithium-thickened grease, worked penetration 265-295 (0.1mm), basic oil viscosity: 190 cSt (mm <sup>2</sup> /s) at 40° C, drop point: 180° C, Working temperatures: - 20° C to + 120° C, designation in accordance with DIN 51825: KP2K-20, active agents: EP additives (for wear-reduction) and ageing protection; water resistant and corrosion protection

A copy of the special publication "Recommended lubricants" is available on request.

**CHECKING PRIOR TO INITIAL OPERATION**

Hoists, including the supporting structure, must be inspected by an appropriately trained and qualified person before initial operation and before re-commissioning after significant modifications. Hoists and lifting gear which are installed in trolleys must be inspected by a specialist.

The inspection covers the proper mounting, equipment level and operational-readiness, in the main, the completeness, suitability and effectiveness of the safety devices as well as the condition of the device, the harness, the equipment and the supporting structure.

Safety devices are braking devices, overload protection devices, EMERGENCY STOP devices, lifting and lowering limiters (emergency end-stop devices).

A description of the inspection can be found in the **Maintenance** section, page 37.

## OPERATION

### RULES FOR SAFE OPERATION OF HOISTS

**As an operator of hoists, you are responsible for your own safety and for that of your colleagues in the working area of the hoist.**

- ▶ Hoists may only be operated by persons charged with this task by their company.
- ▶ Before using the JDN Air Hoist for the first time, familiarise yourself with all permissible operating conditions. For this purpose, read through this operation manual thoroughly and perform the described actions on the crane, step by step.
- ▶ Report each malfunction to your safety officer immediately, so that the fault can be remedied without delay.
- ▶ Adhere to the regulations of the accident prevention authorities (e.g. Berufsgenossenschaft regulations in Germany).
- ▶ Always comply with the information in the **Intended use** section on page 15.

**The following uses are classified as impermissible:**

- ▶ Oblique pulling of loads in general.

#### Definition of oblique pulling

Oblique pulling is the deviation of the load chain and the chain hoist from the vertical position, for a force acting in a straight-line between the point of force application of the load on the load hook and the point of suspension on the supporting structure.



#### Oblique pulling

Under special safety provisions relevant to the particular situation, JDN Air Hoists may be used for oblique pulling (see **Intended use**, page 15).

In this case, a chain box must not be used as the chain may fall out or become knotted.

Oblique pulling is not permitted for hoists installed in trolleys or in running gear. Please contact us, if required.

- ▶ Detaching or dragging of loads.
- ▶ Loading of the hook at the tip.
- ▶ Catching of falling loads.
- ▶ Carrying persons (see **Intended use**, page 13).
- ▶ Jog control with load on the hook.
- ▶ Switching to the opposite direction with load in motion.
- ▶ Operational reaching of lifting and lowering limiters.
- ▶ Allowing the safety clutch to slip following actuation due to overload (PROFI 3 TI - 20 TI, EH 10 - EH 20).
- ▶ Never hold the chain in the area of the centre section under tension at the upper or lower limit position of the load hook.

### **JDN Air Hoists must not be used for the following applications, for example:**

- ▶ Critical areas of nuclear plants.
- ▶ Over acid baths or other facilities containing corrosive substances.
- ▶ In areas in which organic acids are present.

### **To ensure the safety of personnel and property when using JDN Air Hoists, it is essential that the following points are observed:**

- ▶ Lift the load carefully at the beginning.
- ▶ Never touch a running chain.
- ▶ Never use the hoist chain for attaching loads.
- ▶ Never allow loads to fall into the hoist chain.
- ▶ If the chain is slack, do not take up the load at maximum speed.
- ▶ When operating without a chain box, avoid hazards due to idle chain (falling, catching, impacting), see section **Operation without chain box**, page 19.
- ▶ Never apply bending loads to chains.
- ▶ Do not join or repair hoist chains.
- ▶ Do not operate with a chain which is drawn tight, bent or extended.
- ▶ Check blocked chains for damage.
- ▶ Straighten twisted chains (defective bottom block)
- ▶ Do not operate with damaged, worn or rusty chains.
- ▶ Permissible operating temperature for chain and hook: - 40° C to + 150° C, permissible ambient temperature: - 20° C to + 70° C, permissible heat absorption of the hoist body: max. 90° C.
- ▶ Never allow persons to enter the area below the suspended load.
- ▶ Never attempt to remedy a fault with a load suspended from the hoist.
- ▶ Only use suitable and approved attaching aids; do not jam the hook at the point of attachment.
- ▶ Please ensure that the operator is not put at risk within the operating area by attaching aids or the load.
- ▶ Follow the relevant instructions for attaching loads.
- ▶ Before attaching, accurately position the load vertically below the hoist. The chain must hang vertically before lifting.
- ▶ Ensure that the hook safety catch is closed.
- ▶ Before lifting loads, ensure that the maximum permissible load is not exceeded. Attaching aids must be included in the weight of the load.
- ▶ During lifting and lowering, prevent accidents by ensuring that the load remains stable and does not tilt or fall.
- ▶ Never drive against jammed loads.
- ▶ Only use **original JDN chain boxes**.
- ▶ Only lift one load at a time; never several loads simultaneously.
- ▶ Never lock the control elements of the control devices.
- ▶ If the control elements become difficult to operate have the hoist repaired.
- ▶ In the case of power failure, secure the load and the surrounding area, until the power is restored.
- ▶ Never use or repair bent, open or deformed load hooks. The hoist must be repaired and the hook must be replaced.
- ▶ Never anneal the hook.
- ▶ Only operate JDN Air Hoists with **original JDN controls**.
- ▶ Uncontrolled, external force factors (such as due to hydro cylinders, falling loads) are not permitted.
- ▶ Repair damaged hook safety catches.
- ▶ Repair stiff hook bearings.
- ▶ Do not kink or pinch control hoses.
- ▶ Have loosened bolted connections tightened by the Repairs department.
- ▶ Before removing compressed air hoses, shut off the compressed air supply.
- ▶ Do not exceed the permissible capacity of the chain box.
- ▶ Repair the hoist if the braking distance is excessive.
- ▶ If a load is lifted using several air hoists, prevent overloading due to incorrect weight distribution.
- ▶ Select a safe operating location.
- ▶ Ensure the correct system pressure.
- ▶ Never touch metallic hand controls which are colder than 0° C or hotter than 43° C, without suitable protective gloves.
- ▶ Do not make modifications to the hoist.
- ▶ Only use **original JDN spare parts**. J.D. Neuhaus GmbH & Co. KG accepts no liability for the use of non-original components and/or modifications by unauthorised persons.
- ▶ Do not switch on multi-chain hoists if the bottom block is supported.
- ▶ Special safety precautions must be taken when lifting loads into areas which are out of sight.

**DANGER!**

For all air hoist applications, ensure that the load hook can be lowered all the way to the ground, in order to prevent a load being moved to the lower limit position, without reaching the ground. Danger due to overloading.

**DANGER!**

Never use hoists on the ground if they are not specifically intended for horizontal pulling.

**DANGER!**

The fatigue strength of chains is significantly impaired due to extreme corrosion (pitting corrosion). This causes a **danger of fracture**. Hydrogen-induced embrittlement with resultant stress cracks due to highly corrosive media (e.g. sea water) may affect high-strength steels (e.g. chains). Danger of fracture! This process is promoted by so-called recombination poisons. Examples of these are hydrogen sulphide, cyanide, arsenic compounds and rhodanide. If rusty chains are not replaced for operational reasons, crack inspections are to be carried out at intervals of three months.

**Company operating instructions**

In the case of particularly difficult lifting equipment applications, the company must provide comprehensible operating instructions in the language of the operator, within the framework of this operation manual. Here, measures for safe operation are stipulated in accordance with prevailing operating conditions.

Furthermore, it is essential that all the regulations set out in sections **Intended use**, page 15 and **Operating conditions**, page 15, are observed.

**CONTROLS**

JDN Air Hoists can be equipped with a variety of control devices. They are all suitable for use in explosion-hazardous areas.

All control switches return to the zero position when released.

**CONTROL VALVE ON MOTOR**

**Air control (E-, F-, FI-control) with MS**

Control valve with upstream main-stream valve

The control valve consists of:

1. Main-stream valve
2. Direction control valve as rotary valve
3. Positioner (pneumatic actuation)

The main-stream valve lies upstream from the rotary valve. If no control pressure is present, this valve is closed and the rotary valve is depressurised. If control pressure is applied from the hand control, the valve opens and releases the main stream.

If the red EMERGENCY STOP button on the hand control is pressed, all control lines are depressurised and the main-stream valve is closed.

The rotary valve positioner is mechanically connected to the rotary valve drive.  
The positioner is actuated by the control air.

**Air control (E-, F-, FI-control)**

Control valve without upstream main-stream valve

The control valve consists of:

1. Direction control valve as rotary valve
2. Positioner (pneumatic actuation)

The rotary valve positioner is mechanically connected to the rotary valve drive.

The positioner is actuated by the control air.

**Rope control**

Control valve without upstream main-stream valve

The control valve consists of:

1. Direction control valve as rotary valve
2. Positioner

The rotary valve positioner is mechanically connected to the rotary valve drive.

For the purpose of actuation, the rotary valve is directly connected to the control lever.

**E-CONTROL**

With E-control, lifting and lowering movements can be controlled via two pushbuttons. The direction of movement of the load hook is marked on the upper side of the valve housing, above the pushbuttons.

- ▶ Lift: Press the right pushbutton.
- ▶ Lower: Press the left pushbutton.

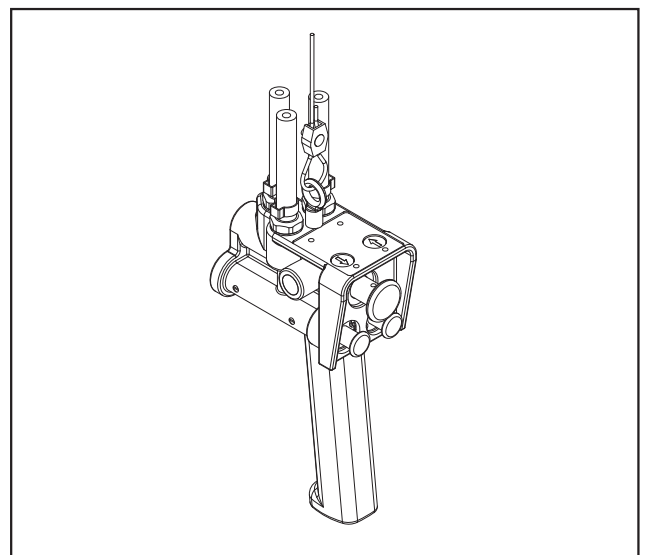

*E-control with EMERGENCY STOP button*



**PUSHBUTTON F-CONTROL**

With pushbutton F-control, lifting and lowering movements can be controlled via two pushbuttons. The direction of movement of the load hook is marked by arrows next to the pushbuttons.

- ▶ Lift: Press the upper pushbutton.
- ▶ Lower: Press the lower pushbutton.

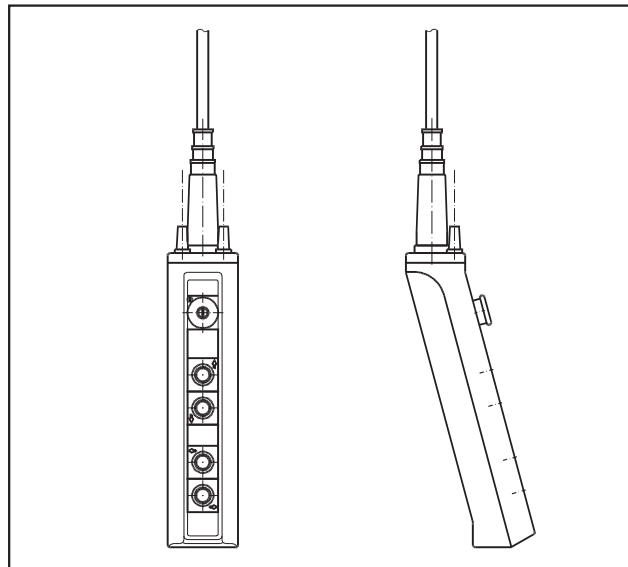

*F-control with EMERGENCY STOP button*

**PUSHBUTTON FI-CONTROL**

With pushbutton FI-control, lifting and lowering movements can be controlled via two pushbuttons arranged side by side. The control pressure is infinitely variable, enabling precise positioning of the load. The direction of movement of the load hook is marked by arrows on the pushbuttons.

- ▶ Lift: Carefully press the right pushbutton. The load is lifted slowly.
- ▶ Press the pushbutton further down in order to increase the lifting speed.
- ▶ Release the pushbutton slightly in order to reduce the lifting speed.
- ▶ Lower: Carefully press the left pushbutton. The load is lowered slowly.
- ▶ Press the pushbutton further down in order to increase the lowering speed.
- ▶ Release the pushbutton slightly, in order to reduce the lowering speed.

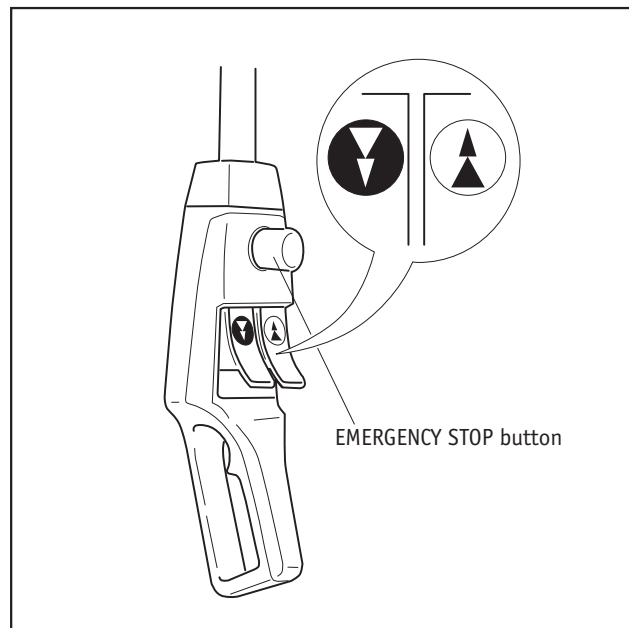

*FI-control with EMERGENCY STOP button*

## EMERGENCY STOP DEVICE

Within the EU, these controls are equipped with an EMERGENCY STOP device (optional outside the EU).

In order to avert danger arising from the lifting movement as quickly as possible, the pushbuttons must be released; the movement of the load is interrupted immediately.

Only in the case of failure of this stop function, must the red EMERGENCY STOP button be firmly pressed. The EMERGENCY STOP button engages. This results in the closing of a separate check valve and the load hook comes to rest instantaneously. The pushbuttons for lifting and lowering now no longer function.

The EMERGENCY STOP button can be released again by turning clockwise. It jumps back into place.



### DANGER!

Never release the EMERGENCY STOP button before the danger has been eliminated and the stop function via the pushbuttons has been restored.

## ROPE CONTROL

With rope control, the lifting and lowering movements are controlled directly. Both rope ends are connected to one another via a handle, enabling precise one-hand operation. The direction of movement is marked by arrows on the handle.

The control elements for rope control and the energy-switching component of the control valve on the motor (reversing valve), are positively connected to one another. This connection is designed in such a way, that in an emergency, the control valve can be reset to a stable neutral position. Thus, no additional EMERGENCY STOP device is required.

- ▶ Lift: Carefully pull on the green rope with the green handle pin. The load is lifted slowly.
- ▶ Pull harder on the rope, in order to increase the lifting speed.
- ▶ Release the rope slightly in order to reduce the lifting speed.

- ▶ Lower: Carefully pull on the red rope with the yellow handle pin. The load is lowered slowly.
- ▶ Pull harder on the rope, in order to increase the lowering speed.
- ▶ Release the rope slightly, in order to reduce the lowering speed.

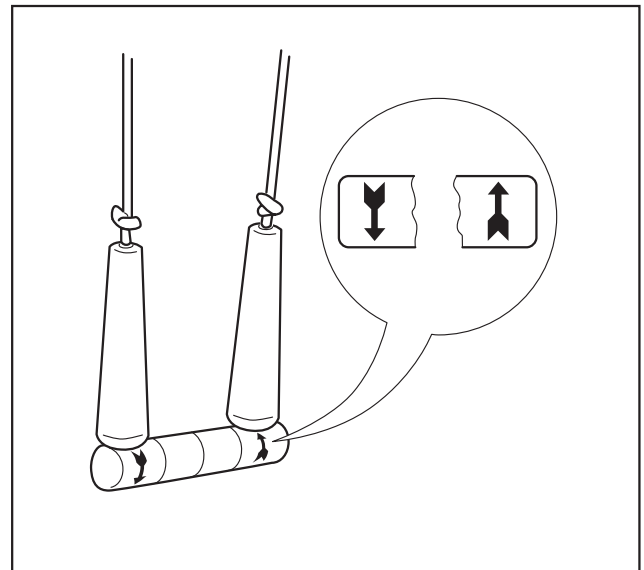

Rope control

## OVERLOAD PROTECTION

Your hoist is equipped with a direct-acting overload protection in the form of a new type of safety clutch. This safety clutch limits overload to 120% of load-carrying capacity, without the danger of failure due to the load running back.

## ATTACHING THE LOAD



### DANGER!

Only use attaching cables or attaching chains which are suitable for the load. Attaching must not be attempted by winding with the lifting chain around the load.

In Germany, the trade association regulations "Operation of load carrying devices used with lifting equipment" (BGR 258) must be adhered to. In other countries, the relevant local regulations must be observed.

- ▶ Attaching aids must be attached at the lowest point of the hook. Never load the point of the hook.
- ▶ Ensure that the hook safety catch is closed.

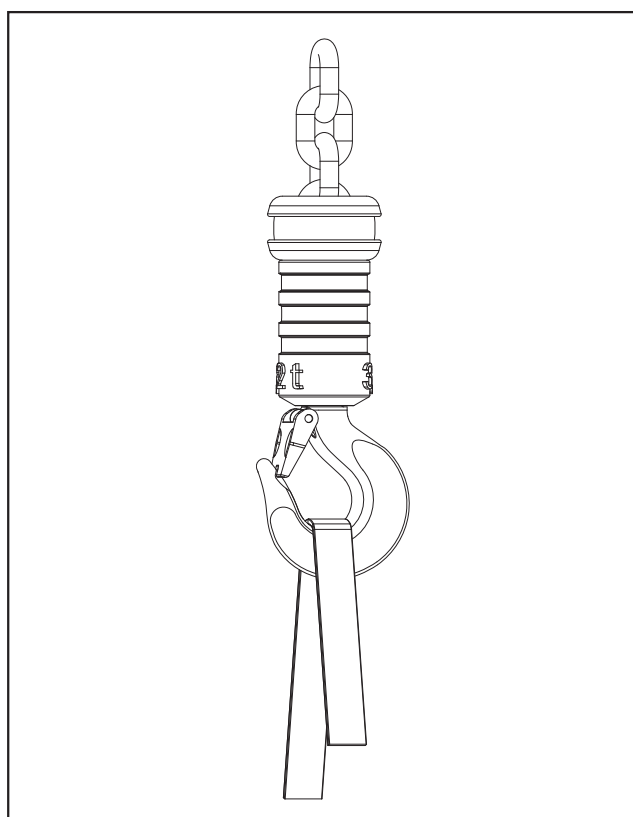

*Attach the load safely*

### LIFTING THE LOAD



#### ATTENTION!

JDN Air Hoists must be capable of alignment under load. Otherwise impermissible additional forces can occur, which can damage the hoist components.

- ▶ First, lift the load hook, in order to pull the slack chain tight. With the chain tight, briefly interrupt the lifting procedure. The hoist can align itself and the material is protected.
- ▶ Then lift the load.

The overload protection system aborts the lifting operation in the event of loads whose weight is more than the pre-defined limit value for the overload protection (see **Overload protection** section, page 59).

### LOWERING THE LOAD



#### DANGER!

Ensure that there are no persons below the load.

- ▶ Then lower the load and ground it carefully.



#### DANGER!

For all air hoist applications, ensure that the load hook can be lowered all the way to the ground, in order to prevent a load being moved to the lower limit position without reaching the ground. Danger due to overloading.

### DETACHING THE LOAD

- ▶ Lower the load hook far enough, so that the load can be easily detached.
- ▶ Move the load hook out of the lifting area in order to avoid hazardous situations.

### INTERRUPTING WORKING

If you wish to interrupt working with your JDN Air Hoist:

- ▶ Set down and detach the load.
- ▶ Move the load hook out of the lifting area in order to avoid hazardous situations.

## TAKING OUT OF OPERATION

### SHUTTING DOWN

If the hoist is to be taken out of operation for a longer period of time it must be protected against corrosion and dirt.

- ▶ Coat the chain and hook with a light oil film.
- ▶ Move the load hook out of the lifting area, in order to avoid hazardous situations.
- ▶ Do not move against the lifting and lowering limiters/ buffer (emergency end-stop devices).
- ▶ Depressurise the air line.

### STORAGE

(see section **Storage conditions**, page 20)

### DISMANTLING



#### **DANGER OF INJURY!**

JDN Air Hoists must only be dismantled by qualified personnel.

- ▶ Depressurise the air line.
- ▶ Provide a suitable working platform.
- ▶ Loosen the union nut and remove the air hose.
- ▶ Protect the air connection against the dirt ingress.
- ▶ Detach the control hoses from the hoist. Do not kink the control hoses.
- ▶ Mark the connections.
- ▶ Detach the strain-relief and hose carrier and remove the control device.
- ▶ Carefully detach/ dismount the hoist and remove.
- ▶ For trolleys, proceed in reverse order to that described in the section on mounting trolleys (in the trolley operation manual).

### DISPOSAL

JDN Hoists contain a range of materials which, on expiry of the service life, must be disposed of or recycled where appropriate, in accordance with statutory regulations.

Please note the following list of materials used:

#### **HOIST**

- ▶ Ferrous materials
  - Steel
  - Nodular cast iron
- ▶ Non-ferrous metals
  - Bronze
  - Aluminium
- ▶ Plastics
  - polyurethane
  - polyoxymethylene
  - polyvinyl chloride
  - polyamide, glass-fibre reinforced
  - natural rubber
  - polypropylene
  - phenol resin
  - thermoset moulding compound (asbestos-free brake lining)
  - synthetic rubber

#### **FILTER SILENCER/ SERVICE UNIT:**

- Zinc diecast
- Brass
- Nitrile rubber
- Aluminium
- Polypropylene
- Polyurethane
- Glass-fibre reinforced plastic
- Steel
- Polyacetal
- Polyethylene

## MAINTENANCE

### MAINTENANCE AND INSPECTION INTERVALS

JDN Air Hoists are extremely robust and require little maintenance. Compliance with maintenance and inspection intervals is of great importance in order that the hoist operates safely and reliably over a period of many years.



#### CAUTION!

Maintenance work on JDN Air Hoists must only be performed by trained and qualified personnel.

### CLEANING AND CARE

If your JDN Air Hoist is often used at different locations, particularly in dirty and damp environments,

- ▶ clean any dirt off the hoist and the chain,
- ▶ seal off the air supply connections,
- ▶ protect the hoist and, in particular, the chain from corrosion,
- ▶ store the hoist in a clean and dry place.

### SPARE PARTS

If, during repair work, the replacement of components is necessary, only **original JDN spare parts** may be installed.

### LUBRICANTS

(see section **Lubricants**, page 27)

### INSPECTION AND REPAIRS

Series lifting equipment is classified into groups and dimensioned according to the type of operation (Driving mechanism classification according to ISO/FEM).

The classification is determined by the average daily operating time and the load spectrum. This is provided that the lifting and lowering paths are approximately the same.

For devices used mainly in vertical operation (from 75 % of on-time), the theoretical operating time is reduced due to the higher lowering speed in the range from 50 % to 100 % of the nominal load.

Therefore, the determined portion of the theoretical operating time must be multiplied by a factor of  $f_v$ .

The factor  $f_v$  has a value of 1 to 50 % of the nominal load, increasing linearly to 1.5 at 100 % of the nominal load (nominal load percentage P).

$$f_v = 1 + 0.5 \frac{P - 50}{50} \quad (\text{for } P > 50\%)$$

In order to achieve safe operating periods, the company must check that the theoretical operating time has been achieved during each inspection, by the person responsible. This must be documented in the inspection log at least once annually. The inspection log is only supplied in the Federal Republic of Germany. Instructions and a **model for determining the actual operating time** can be found from page 39 onwards.

When the theoretical operating time has been reached, a general overhaul must be performed. Detailed explanations for the determination of the actual operating time and its documentation can be found in the national safety regulations. Alternatively, the calculation model in this operation manual can be used. The general overhaul must be initiated by the operator and must be documented in the inspection log. Information on general overhaul can be requested from the manufacturer.

Only if the group classification corresponds to the actual type of operation of the lifting equipment, does a safe operating period conform to the theoretical operating time. Deviations of the actual type of operation from that used for calculation extend or shorten the safe operating period.

For all inspection work which is not a part of the daily inspection, suitable access must be made to the hoist. The hoist must be disconnected from the main air supply during assembly work.

**Dismantling** the hoist, see page 36.



**CAUTION!**

Following each repair, the hoist must be checked for operational readiness.

**INSTRUCTIONS CONCERNING THE "MODEL FOR DETERMINING THE ACTUAL OPERATING TIME"**

The decisive factors for the type of operation are the collective loads with different cubic averages  $k$ . The collective load indicates to what degree a driving mechanism, or a part of one, is subjected to its maximum stress or only to smaller stresses. The cubic average (factor of the load spectrum) is calculated using the following formula.

$$k = \sqrt[3]{(\beta_1 + \gamma)^3 \cdot t_1 + (\beta_2 + \gamma)^3 \cdot t_2 + \dots + \gamma^3 \cdot t_\Delta}$$

Definitions:

$$\beta = \frac{\text{Maximum or ultimate load}}{\text{Load-bearing capacity}}$$

$$\gamma = \frac{\text{Dead load}}{\text{Load-bearing capacity}}$$

$$k = \frac{\text{Operating time with maximum load or partial load and dead load}}{\text{Total operating time}}$$

$$t_\Delta = \frac{\text{Operating time with dead load}}{\text{Total operating time}}$$

The formula given for the cubic average  $k$  does not take the weight of the harness into account. This is permissible if the ratio

$$\frac{\text{Weight of harness}}{\text{Load-bearing capacity}} \quad 0.05$$

To determine the type of operation for calculating the partial operating times (actual operating time), the following collective load diagrams can also be used.

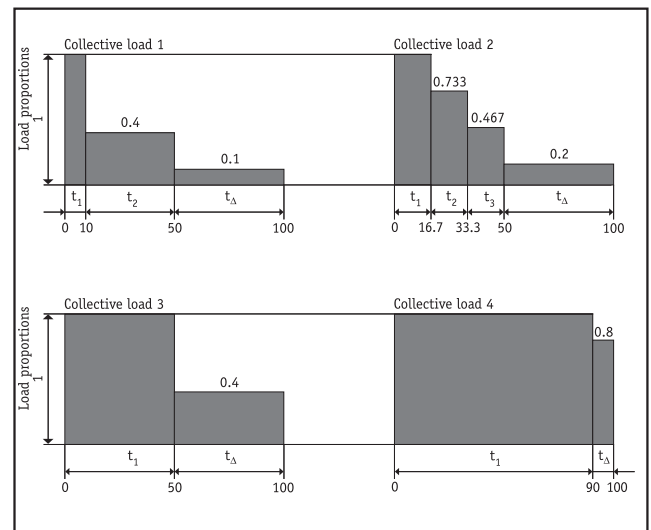

The FEM\* 9.511 rule differentiates between four collective loads, which are identified by the definitions and by the ranges of the cubic averages  $k$ . This classification complies with ISO 4301/1.

\*FEM = Federation Europeene de la Manutention (European Federation of Materials Handling and Storage Equipment)

Collective load		Definition	Cubic average	Collective load factor
1 (low)	<b>L1</b>	Driving mechanisms or parts thereof, which are only subject to the maximum stress in exceptional circumstances, and are only subject to very low stresses continuously.	$k \leq 0.50$	$k_m = k^3 = 0.125$
2 (average)	<b>L2</b>	Driving mechanisms or parts thereof, which are subject to the maximum stress often, and are only subject to low stresses continuously.	$0.50 < k \leq 0.63$	$k_m = k^3 = 0.25$
3 (high)	<b>L3</b>	Driving mechanisms or parts thereof, which are often subject to the maximum stress and are subject to average stresses continuously.	$0.63 < k \leq 0.80$	$k_m = k^3 = 0.5$
4 (very high)	<b>L4</b>	Driving mechanisms or parts thereof, which are regularly subject to the maximum stress of adjacent stresses.	$0.80 < k \leq 1.00$	$k_m = k^3 = 1$





The specified inspection intervals are valid for use in accordance with the classification (see driving mechanism classification on the nameplate). The service life is approx. 10 years if the device is used in accordance with its classification. If the hoist is used more intensively the intervals are to be shortened accordingly. The intensity of use must be assessed using the **model for determining the actual operating time** (see page 39). All operating hours are translated into full load hours. The theoretical operating time and the interval hours are indicated in full load hours.

Maintenance measure	Interval	Comment
Check oil level for motor lubrication (when operating with oiler)	Daily	( <b>Filling and adjusting oiler</b> section, page 47)
Lubricate the chain	As required	( <b>Lubricating the chain</b> section, page 43)
Visually check the chain	Weekly	

Inspection measure	Interval	Comment
Check control device	Daily	( <b>Checking controls</b> section, page 44)
Checking braking function	Daily	( <b>Checking braking function</b> section, page 43)
Checking direction of movement	Daily	( <b>Checking direction of movement</b> section, page 44)
Check lifting and lowering limiters (buffers) visually	Daily	Replace buffer immediately if damaged, otherwise replace every 5 years
Check EMERGENCY STOP function	Daily	
Check chain	Every 3 months	( <b>Checking chain, chain sprocket and chain guides</b> section, page 54) In the event of wear promoting operating conditions, reduce intervals between checks
Check lifting and lowering limiters	Annually	( <b>Checking lifting and lowering limiters</b> section, page 43)
Check brakes with load	Annually	Load must be braked reliably ( <b>Checking braking function</b> section, page 43)
Check all the bolted and pin connections	Annually	
Check load hook on load a. carrying side	Annually	( <b>Check dimensions</b> section, page 55)
Check the motor, check, clean and grease the control valve (JDN high-performance grease)	Annually	Measure the lifting speed
Check the axial movement of the hooks and eyes	Annually	( <b>Checking axial play</b> section, page 56)
Check the service unit <sup>1</sup>	Annually	( <b>Service unit</b> section, page 45)
Check the silencer for permeability	Annually	( <b>Checking silencer for permeability</b> section, page 44)
Check overload protection	Annually	( <b>Checking and adjusting overload protection</b> section, page 59)
Check compressed air connections for damage	Annually	

<sup>1</sup> If appropriate

Inspection measure	Interval	Comment
Check sealing efficiency and function of control valve	Annually	
Check condition of the chain box <sup>1</sup> including mountings	Annually	( <b>Chain box</b> section, page 63)
Check for brake wear and motor vane wear	Every 200 hours, at least every 5 years	(Replacing brake disc, brake piston and vanes section, page 48), replace motor vanes every 5 years
In off-shore areas and other similar corrosive environments, replace the chain regularly	Every 5 years	
Check gearbox and perform lubricant change	Every 5 years	
Check the rotor/pinion shaft connection and lubricate with gear grease	Every 5 years	
Check the chain sprocket bearings and lubricate if necessary	Every 5 years	
Check chain sprocket and chain guides	Whenever chain is replaced	( <b>Wear dimensions</b> section, page 56)
Renew grease lubrication of motor	When required, at least every 5 years	( <b>Motor lubrication</b> section, page 48)

<sup>1</sup> If available

For monorail hoists, also refer to "Maintenance and inspection measures" in the **Trolley operation manual**.

**LUBRICATE THE CHAIN**

The chains of JDN Air Hoist must be lubricated in the links, in unloaded condition.

- ▶ Clean heavily contaminated chains.
- ▶ Lay the chain in a suitable container.
- ▶ Spray the chain with special lubricant or motor vehicle engine oil.

If you wish to lubricate the hanging chain, ensure that the chain links are oiled at the points of contact. For this purpose, move the chain to and for.

A high-performance lubricant in an aerosol can is available from JDN, which adheres well to the chain after the solvent has evaporated and does not drip off, Art. no. 12066 (aerosol 400 ml).

For operation in areas with high corrosion potential, e.g. in the off-shore sector, the chain can be largely protected against corrosion by the use of special lubricants.

These types of lubricants are characterised by weathering resistance, water insolubility, good adhesion properties etc.

Re-lubrication intervals must be stipulated in accordance with the loading. Please contact us, if required.

**CHECKING BRAKING FUNCTION**

Check the function of the brake daily as follows:

- ▶ Switch the unloaded air hoist alternately between lifting and lowering modes.

If a control element is released, the chain must be seen not to run on.



**DANGER!**

If the chain runs on, do not use the hoist. The hoist must be repaired.

For physical reasons, the braking distance cannot have the value zero. However, for the purpose of this functional check, running on of the chain must not be perceptible. When checking the braking function under nominal load, the following braking distances must not be exceeded:

**BRAKING DISTANCES UNDER NOMINAL LOAD (LOAD-CARRYING CAPACITY) AFTER LOWERING HAS BEEN STOPPED**

Type	3 TI	6 TI	10 TI EH 10	16 TI EH 16	20 TI EH 20
Rope control	36	15	18	10	8
All others Controls with hose lengths of 2 m	48	22	26	14	11

Dimensions in mm

If the control hoses are long the braking distances will increase due to longer air evacuation times.

**CHECKING LIFTING AND LOWERING LIMITERS**

- ▶ Move the unloaded load hook until just short of the upper and lower end positions.
- ▶ Stop immediately before reaching the end position and then carefully (by repeatedly pressing the control element) move to the end position.
- ▶ The movement of the chain must be stopped due to deformation of the buffer and activation of the safety clutch. The motor is however not switched off (only allow the safety clutch to act for a short time).
- ▶ Following successful testing, the buffer must be unloaded.



**DANGER!**

If the buffer is damaged, do not use the hoist. The hoist must be repaired (replace the buffer).

### CHECKING CONTROLS AND EMERGENCY STOP FUNCTION

All control elements of the controls must always be free-moving.

- ▶ Unload the JDN Air Hoist.
- ▶ Briefly actuate and release all control elements of the controls one after another. The control elements must return to their initial positions immediately. The switching on and off function must operate correctly.
- ▶ PRESS the EMERGENCY STOP button. Each movement of the hoist must stop. Actuation of the control elements must not cause a lifting or lowering movement.
- ▶ RELEASE the EMERGENCY STOP button by turning.



**DANGER!**

If a control element is stiff or remains in the actuated position, do not use the hoist. The controls must be repaired.

### CHECKING THE MAIN AIR EMERGENCY-STOP VALVE

The main air emergency-stop valve is opened with each actuation of the controls. It closes when the controls are released.

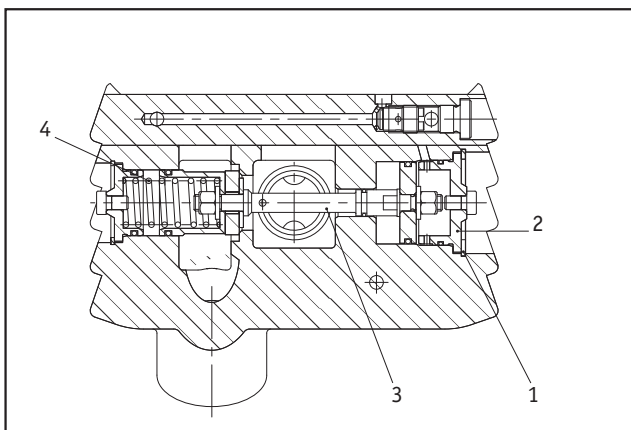

Main air emergency-stop valve

With each check, the working order of the valve must be examined as follows:

- ▶ Shut off the compressed air supply and unload the line.
- ▶ Remove retaining ring 1.
- ▶ Pull out cover 2.
- ▶ Press plunger 3 inwards against the force of spring 4. It must return again due to the spring force.
- ▶ If the plunger does not move, the valve must be repaired.

### CHECKING DIRECTION OF MOVEMENT

- ▶ Check that the direction of movement of the load hook corresponds to the direction indicated by the arrows on the control elements.

### CHECK THE SILENCER FOR PERMEABILITY

Independent of the stipulated inspection intervals, the silencer must be checked for permeability if the hoist does not achieve the specified lifting speed (see **Technical data** section, page 64 and 66).

The test is performed by comparing the lifting speeds under nominal load, with and without the silencer. The speed with standard silencer or filter silencer must be at least 80% of the lifting speed without a silencer element. In the event of lower values, the silencer elements must be cleaned or replaced.

**SERVICE UNIT**



**ATTENTION!**

If a hoist is operated with a service unit, this should not be mounted further than 5 m away from the hoist.

The ambient temperature must be a minimum of 0° C. It must not exceed 50° C.

**NOTE:** If, at the request of the customer, a service unit is installed in hoists in motorised trolleys and lifting gear, it will be configured at the factory.

A maximum connecting pressure of 10 bar is permitted for the service units supplied by JDN. Higher pressures must be reduced to a permissible value, upstream of the service unit.

The service unit consists either of two elements, filter controller and oiler, or of the filter controller only.

**CHECKING AND ADJUSTING THE FILTER CONTROLLER\*)**

The filter controller is set to an actual pressure of 5.4 bar (3.6 bar) in the factory (actual pressure when lifting the nominal load). In this setting, the manometer can indicate a pressure of over 6 bar (4 bar) with the motor switched off. For correct adjustment, a pressure of at least 7 bar (5 bar) upstream of the service unit is required.

- ▶ Lift the regulator knob.
- ▶ Turn the regulator knob until the manometer indicates a pressure of 5.4 bar (3.6 bar). Clockwise: higher pressure, Anti-clockwise: lower pressure
- ▶ Lock the regulator knob by pressing it down.

Alternatively, the filter controller can be set to a pressure of 6 bar (4 bar) in the absence of an air stream. This setting is only correct for a pressure of at least 7 bar (5 bar) upstream of the service unit.

- ▶ Depressurise the air line downstream of the service unit and close it again.
- ▶ Turn the regulator knob anti-clockwise, in order to release the adjusting spring.
- ▶ Turn the regulator knob until the manometer indicates a pressure of 6 bar (4 bar). Clockwise: higher pressure Anti-clockwise: lower pressure

- ▶ Lock the regulator knob by pressing it down.

\*) Values for 4-bar hoists in brackets

If the nominal pressure of 5.4 bar (3.6 bar) cannot be achieved despite a sufficiently high pressure upstream of the service unit, then the air line cross-section is too small.



*Filter regulator and oiler*

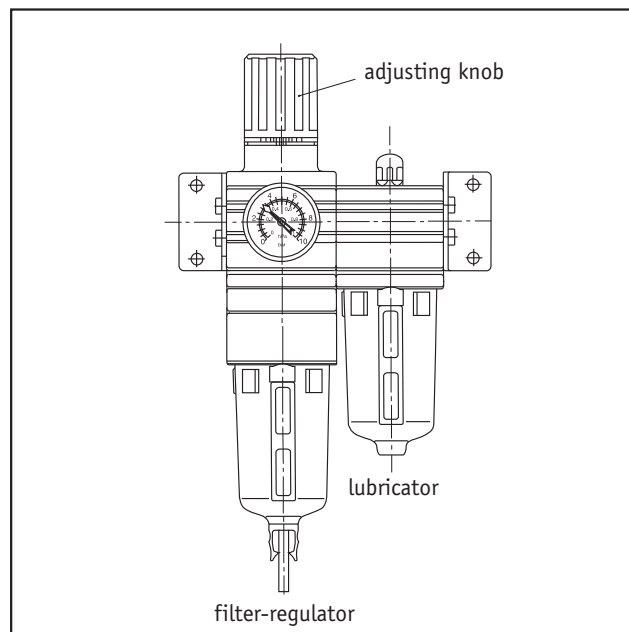

**DRAINING CONDENSATE**

After a certain time, condensate collects in the filter regulator container, which must be regularly drained. Check the condensate level through the sight glass in the filter container. The condensate level must not reach the separating plate.

The container can be emptied manually or semi-automatically, depending on the setting of the drain valve:

- ▶ **OFF position**  
The drain valve is closed in this position. The OFF position is generally set at the factory.
- ▶ **ON position**  
The condensate can be drained manually in this position. Operate the drain valve by pressing upwards (see Figure).  
When the compressed air supply is connected, the drain valve is under pressure. We recommend using suitable splash protection (cloth, fleece) as the condensate will otherwise escape uncontrollably. Collect the escaping condensate and dispose of it as it may contain oil.
- ▶ **AUTO position**  
In this position, semi-automatic condensate drainage takes place. When the pressure upstream of the service unit falls below 0.2 bar, the container empties automatically. With this setting it must be ensured that a suitable container is in place to collect the escaping condensate when drainage occurs.

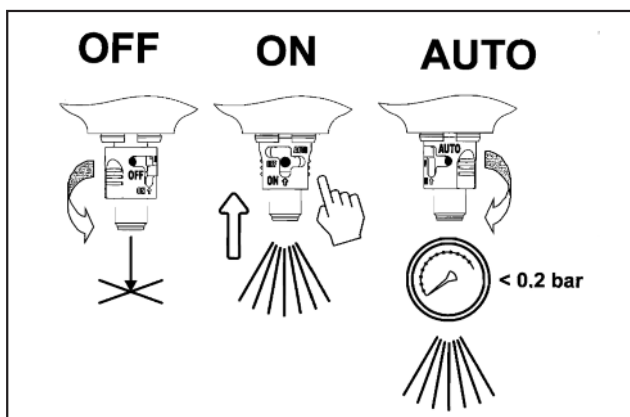

**CLEANING THE FILTER ELEMENT**



**ATTENTION**

Do not use alcohol for cleaning the service unit. Alcohol can damage parts of service unit. Transparent components must only be cleaned using soap solution.

The filter element must be cleaned once annually. For this purpose, proceed as follows:

- ▶ Drain the water.
- ▶ Shut off the main air supply and carefully allow the residual pressure to dissipate.
- ▶ Unlock the filter regulator container, turn anti-clockwise to the stop and remove.
- ▶ Unscrew the separating plate. The filter is located loosely on the separating plate centring device.
- ▶ Clean the filter element using soap solution and blow through forcefully.
- ▶ Reinstall the clean filter element and fasten the separating plate.
- ▶ Insert the filter regulator container in the housing and turn clockwise. The container locks automatically.

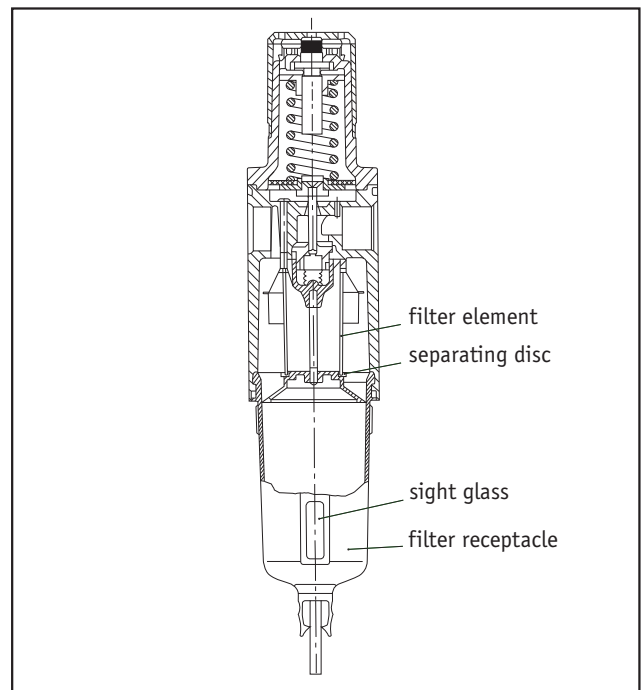

*Cleaning the filter element*

**FILLING AND ADJUSTING OILER**

The oiler ensures that the hoist air supply is consistently provided with a precisely-metered quantity of oil. Regular checking of the oiler is very important, as the vane motor may be damaged in the case of lubricant deficiency. The oiler can also be refilled under pressure.

- ▶ Check the oil level through the sight glass in the container. The oil level must not fall below the minimum mark.
- ▶ Remove the oil filler screw.
- ▶ Fill the container with oil up to the maximum mark and refit the oil filler screw.
- ▶ Check the oil drop rate at the sight glass with the motor running.
- ▶ Turn the oil throttle screw using a screwdriver until the desired number of drops per minute is achieved. Turning clockwise reduces the amount of oil; turning anti-clockwise increases the amount of oil.

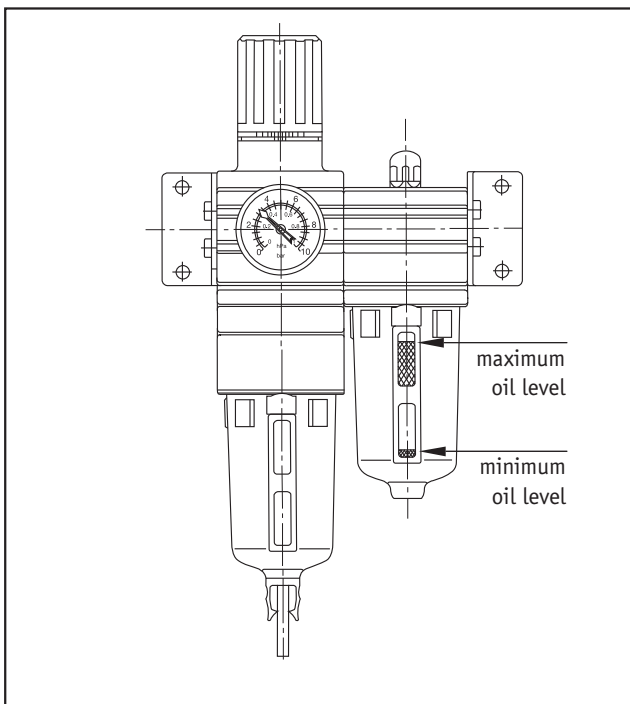

*Check the oil level and top up if necessary*

**Oil drop rate (lifting without load):**  
10 drops per minute.



**ATTENTION!**

Operation of service units with synthetic oils is not permissible. They must also not be connected to compressed air circuits, which are supplied by compressors lubricated with synthetic oil.



**CAUTION!**

J.D. Neuhaus only supplies standard spray oilers. Do not use microspray oilers as very finely secreted oil spray could adversely affect the surrounding air and therefore the respiratory system.

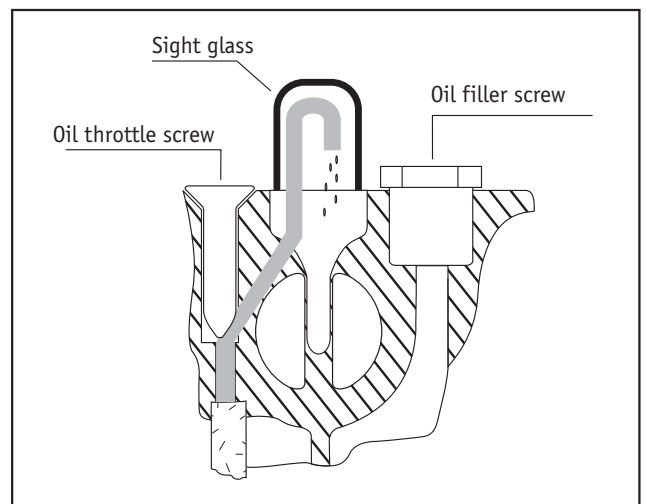

*Check oil drop rate at sight glass and adjust*

**REPLACING BRAKE DISC, BRAKE PISTON AND VANES/MOTOR INSTALLATION/MOTOR LUBRICATION**

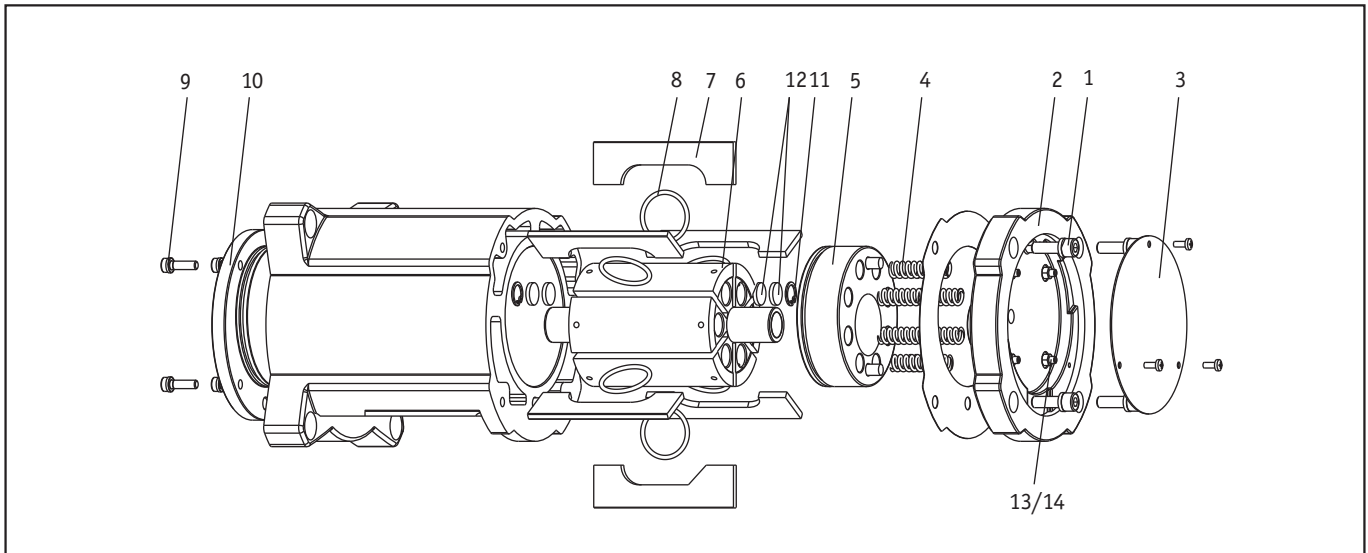

*Replacing brake discs, brake piston and vanes/Motor installation*

The motor and brake functions are achieved in part by means of shared components. The braking action is applied at the lateral surfaces of the rotor. The rotor is pressed via spring force from the cover-side of the motor against a second braking surface located on the opposite side by means of a piston on which braking material is bonded.

**REMOVAL**

Proceed as follows when removing the motor with the brake:

- ▶ Unload the hoist and disconnect it from the main air supply.
- ▶ Detach the control valve from the motor (in order to permit removal of the motor retaining bolts).
- ▶ Detach the motor from the hoist.
- ▶ Remove the motor cover bolts **1** and remove the motor cover **2** with the nameplate **3**. (When the cover bolts are removed, brake spring tension **4** is fully released).
- ▶ Remove the springs.
- ▶ Remove the brake piston **5** from the internal cylinder integrated in the motor housing.
- ▶ Pull out the rotor **6**, removing the vanes **7** and starting aids **8**.

**Note:** If you only wish to check for vane wear or replace the vanes with the starting aids, please continue with the section "Checking for vane wear".

- ▶ Remove the cover bolts **9** and remove the cover with the brake lining **10** (brake disc).
- ▶ Check the braking surfaces of the brake piston and the cover with the brake lining for wear and damage, replace if necessary. The circular wear pattern in the braking surfaces must not be deeper than 0.2 mm. The extremely low-wear braking material will not reach the wear limit of 0.2 mm within the design-dependent service life of the hoist, under intended use. Should the wear limit be reached prematurely, the actual compressed air pressure must be checked with the device switched on (the brake drags in the event of insufficient pressure).
- ▶ Checking vane wear (see illustration **Checking vane wear**, page 49). When the air motor vanes are worn, the motor power and consequently the lifting performance of the JDN Air Hoist are reduced. Replacing the vanes together with the starting aids.



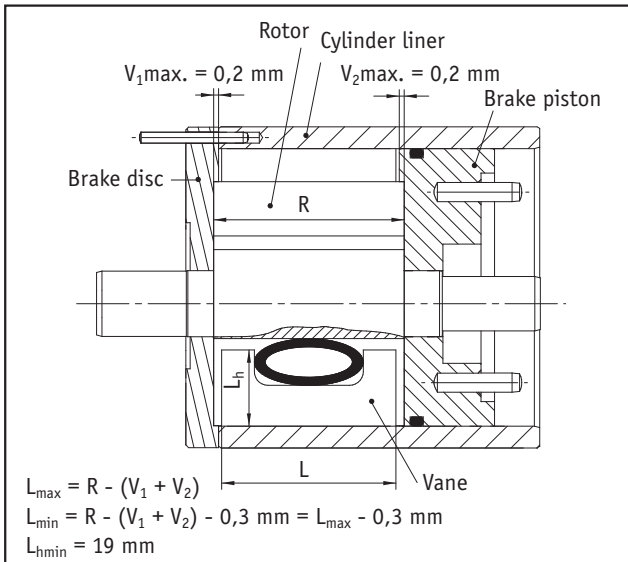

*Checking vane wear*

- ▶ Renew grease lubrication of motor. The grease packing in the rotor chambers is sufficient for approx. 250 operating hours. For this time interval the load on the hoist (collective load) is immaterial. **Note:** The rotor chambers only empty by approx. 60%. In this condition, refilling must be performed. The retaining rings **11** and Vyon washers **12** must be removed in order to refill the chambers. Then pack the lubricant chambers with high-performance lubricant (JDN Art. no 11901) without forming cavities.

Use new round plates to close off the lubricant chambers and secure these using retaining rings.

**ASSEMBLY WITH ADDITIONAL BASIC MOTOR LUBRICATION**

- ▶ Fit the cover with the brake lining, inserting the anti-twist device (pin). Coat the braking surface and rotor bearing (needle bush) lightly with high-performance grease.
- ▶ Tighten the cover bolts.
- ▶ Coat the internal cylinder of the housing lightly with high-performance grease.
- ▶ Coat the entire rotor lightly with high-performance grease and insert into the front rotor bearing with the clutch side first.
- ▶ Coat the vanes lightly with high-performance grease and insert into the rotor slots with the starting aids.
- ▶ Coat the braking surface and the outer diameter

including the brake piston seal lightly with high-performance grease and push the brake piston with the braking surface first into the internal cylinder; note the position of the eccentric bore.

- ▶ Insert the brake springs into the bores of the brake piston.
- ▶ Detach the nameplate from the motor cover.
- ▶ Loosen adjusting bolts **13** and lock nuts **14**. Screw back adjusting bolts.
- ▶ Apply high-performance grease lightly to rotor bearing (needle bush) in the motor cover and install motor cover, ensure correct seating of the brake springs and locating pins to motor housing and brake piston.
- ▶ Do not tighten the 4 adjusting bolts after bolting the motor cover in place, only screw them in loosely to the stop in the cover. Screw back the lock nuts sufficiently beforehand.
- ▶ Then screw back the adjusting bolts 45° to 60° from the stop, hold, and lock with the nuts. For operation in areas with ambient temperatures exceeding 30°C, the adjustment must be carried out with the device warmed up accordingly. For lifting heights of 10 m and more, the setting must be at least 60°C.
- ▶ Screw on the nameplate.
- ▶ Initially fasten the motor, then the control valve to the hoist.



**ATTENTION!**  
**Tightening torques**, see E-list.



**CAUTION!**  
Check the braking action of the hoist under load (run in the brake by performing several hoisting cycles, then assess) prior to initial operation. Check the motor power. In the event of low motor power, regulate the adjusting bolts again.

**REMOVING AND INSTALLING LOAD SLEEVE,  
BOTTOM BLOCK, CLAMP AND BUFFER**

**REMOVING AND INSTALLING LOAD SLEEVE  
AND BUFFER**

- SINGLE CHAIN HOIST (3 TI)

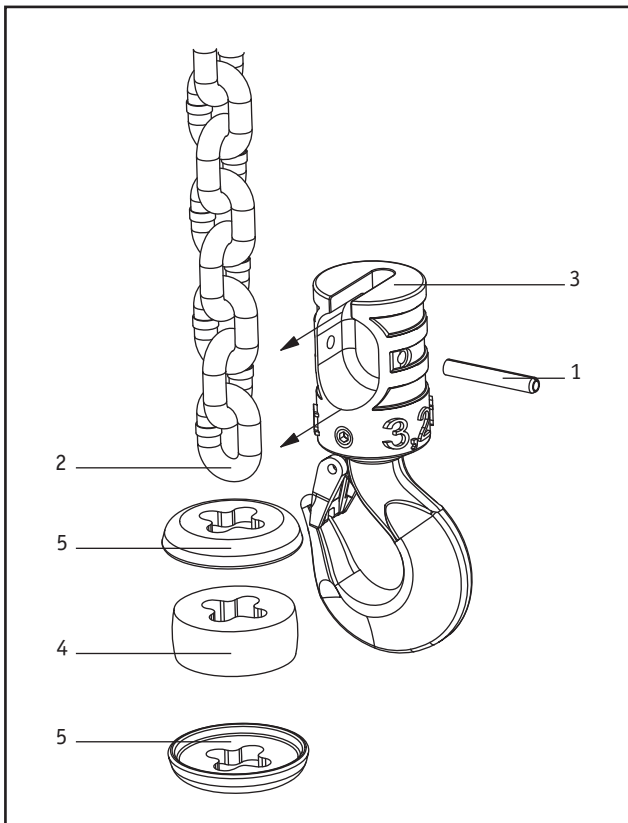

**Removal**

- ▶ Drive out the roll pin 1 for securing the chain from the load sleeve 3.
- ▶ Remove the chain link 2 from the chain pocket.
- ▶ Detach the buffer 4 and buffer discs 5 from the chain.

**Assembly**

- ▶ Push the buffer discs (edge encloses buffer) and the buffer onto the chain.
- ▶ Insert the end chain link into the chain pocket of the load sleeve (position of the weld must align with that of the following links).
- ▶ Drive in a new roll pin to secure the chain link in the load sleeve.

**LOAD SLEEVE IN SPECIAL DESIGN  
WITH CLAMPING PIECE**

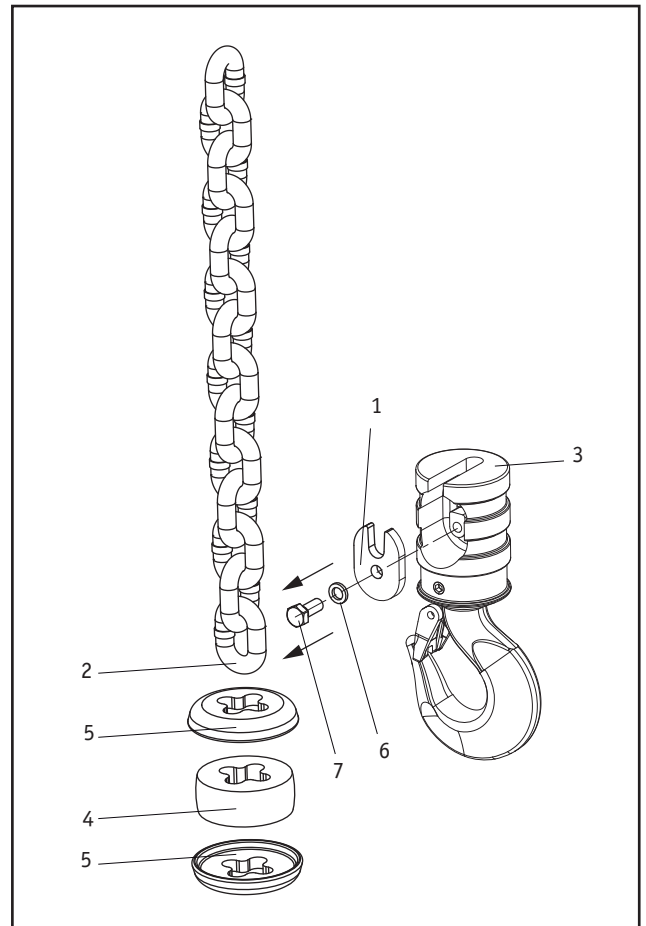

**Removal**

- ▶ Loosen screw 7 and take it out of the chain pocket together with locking washer 6 and clamping piece 1
- ▶ Remove the chain link 2 from the chain pocket.
- ▶ Detach the buffer 4 and buffer discs 5 from the chain.

**Assembly**

- ▶ Push the buffer discs (edge encloses buffer) and the buffer onto the chain.
- ▶ Insert the end chain link into the chain pocket of the load sleeve (position of the weld must align with that of the following links).
- ▶ Insert the clamping piece 1 into the chain pocket, tighten screw 7 with locking washer 6 (41Nm).

**REMOVING AND INSTALLING BOTTOM BLOCK AND BUFFERS**

**- DOUBLE CHAIN HOISTS (6 TI, 10 TI, EH 10)**

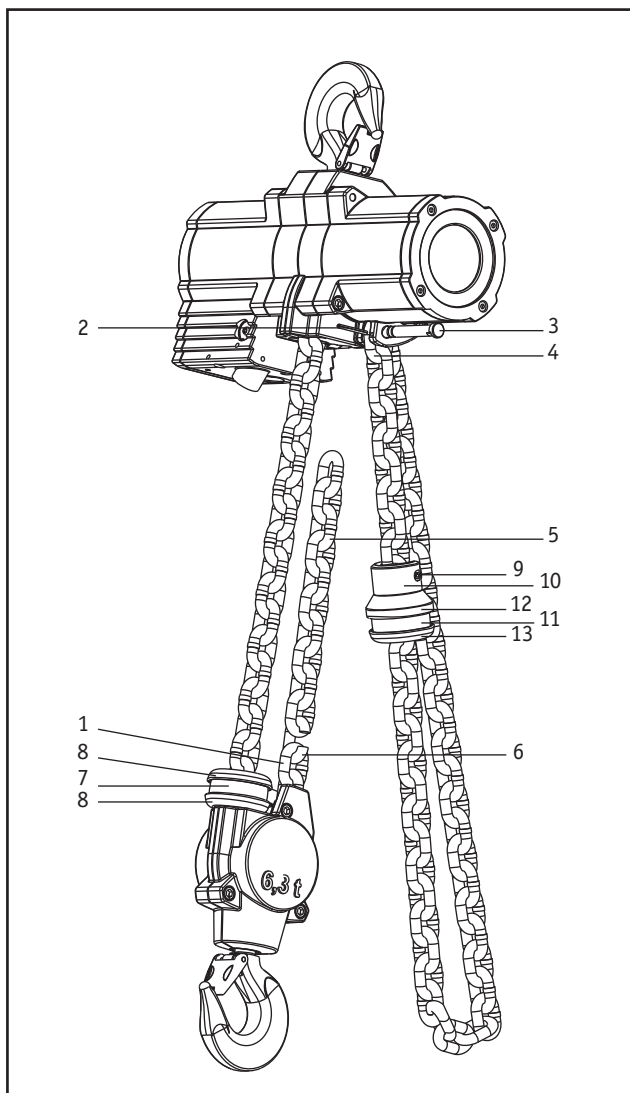

**Removal**

- ▶ Move the bottom block as close as possible to the hoist body.
- ▶ Position the bottom block securely in order to prevent the chain from unravelling uncontrollably causing the bottom block to fall.

- ▶ Remove the chain link 1 of the bottom block from the chain mount on the hoist body by driving out the roll pin 2 and pull out the chain link pin 3 (the end chain link 4 of the idle chain is released simultaneously) or only pull out the chain link pin to the extent that the end chain link of the idle chain is not released from the hoist body. In versions with chain box, the idle chain is not attached to the hoist body.

**Note:** For assembly, it is helpful to fasten a short assembly chain 5 to the end of the chain by means of an open chain link 6 before pulling the chain out of the bottom block. This assembly is pulled into the bottom block as the chain is pulled out and remains there until assembly is completed.

- ▶ Pull out the chain from the bottom block. The buffer 7 and buffer discs 8 are thereby pulled from the chain.

**Assembly**

- ▶ Push the buffer discs (edge encloses buffer) and the buffer onto the chain.
- ▶ Align the chain and fasten it to the assembly chain in the bottom block by means of the open chain link.
- ▶ Pull the chain through the bottom block and detach the assembly chain and the open chain link from the chain. If no assembly chains have been used, the end of the chain must be inserted into the bottom block and pulled through by turning the sprocket wheel using an auxiliary tool.
- ▶ If the chain link pin was not completely pulled out, only align the bottom block chain and push the chain link pin through the chain link to be attached (position of the weld must align with that of the following links). If the chain link pin was pulled out completely, align the bottom block chain and the idle chain and push the chain link pin into the hoist. It must first be guided through the end link of the idle chain and then through the end link of the bottom block chain (position of the weld must align with that of the following links).
- ▶ Drive in a new roll pin to secure the end link pin.

- TREBLE CHAIN HOISTS (16 TI, EH 16)

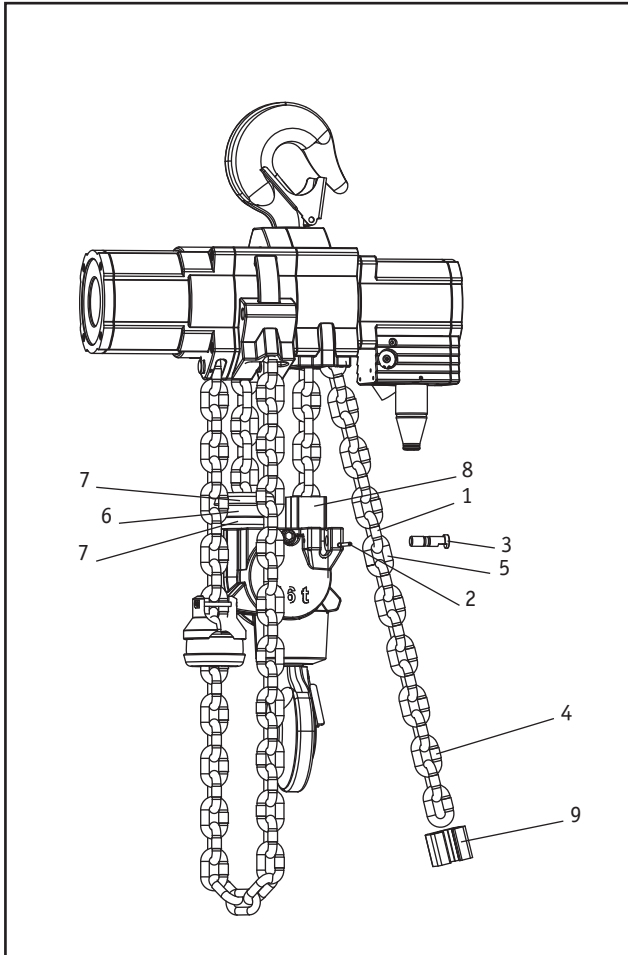

**Removal**

- ▶ Move the bottom block as close as possible to the hoist body. Position the bottom block securely in order to prevent the chain from unravelling uncontrollably causing the bottom block to fall.
- ▶ Remove the bottom block end chain link 1 from the chain mount on the bottom block; drive out the roll pin 2 and remove the end chain link pin 3 for this purpose.

**Note:** For assembly, it is helpful to work with two short assembly chains 4 which are fastened by means of an open chain link 5 to the hoist chain being pulled out during removal of the chain and are pulled successively over the deflection sprocket of the centre section and the bottom block. They remain there until assembly is completed.

- ▶ Pull the chain from the deflection sprocket of the centre section and from the bottom block. The buffer 6, the buffer discs 7 and the run-on elements 8 and 9 are thereby pulled from the chain.

**Assembly**

- ▶ Push the buffer assembly (buffer 6 plus buffer discs 7, edge encloses buffer) onto the chain.
- ▶ Align the chain and fasten it to the assembly chain in the bottom block by means of the open chain link.
- ▶ Pull the chain through the bottom block and detach the assembly chain and the open chain link from the chain.
- ▶ Push the first run-on element 8 onto the chain.
- ▶ Align the chain and pull through the centre section by means of the assembly chain.
- ▶ Detach the assembly chain and the open chain link from the chain.
- ▶ If no assembly chains have been used, the end of the chain must be inserted into both the bottom block and the centre section and pulled through by turning the deflection sprockets using an auxiliary tool.
- ▶ Push the second run-on element 9 onto the chain.
- ▶ Align the chain and fasten the chain link to the bottom block by means of the end link pin (position of the weld must align with that of the following links).
- ▶ Drive in a new roll pin to secure the end link pin.

**QUADRUPLE CHAIN HOISTS (20 TI, EH 20)**

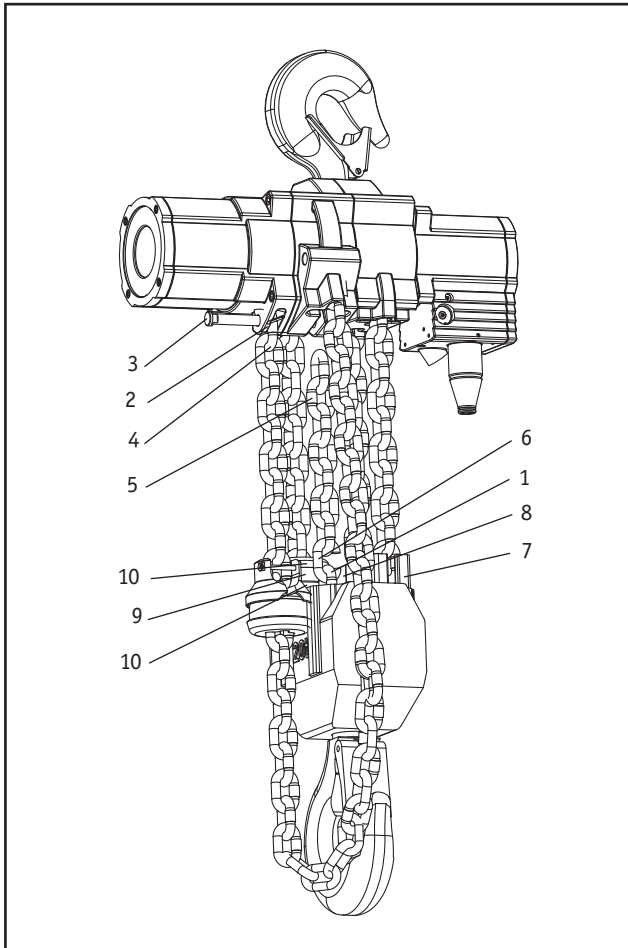

**Removal**

- ▶ Move the bottom block as close as possible to the hoist body. Position the bottom block securely in order to prevent the chain from unravelling uncontrollably causing the bottom block to fall.
- ▶ Remove the bottom block end chain link 1 from the chain mount on the hoist body; drive out the roll pin 2 and remove the end chain link pin 3 for this purpose. In the case of the PROFI 20TI the end chain link 4 of the idle chain is released simultaneously or only remove the end chain link pin far enough to ensure that the end chain link of the idle chain is not released from the hoist body.

In versions with chain box, the idle chain is not attached to the hoist body.

**Note:** For subsequent assembly, it is helpful to work with three short assembly chains 5 which are fastened by means of an open chain link 6 to the hoist chain being pulled out during removal of the chain and are pulled successively over the deflection sprocket of the centre section and the bottom block. They remain there until assembly is completed.

- ▶ Pull the chain from the deflection sprocket of the centre section and from the bottom block. The run-on elements 7 and 8, as well as the buffer 9 and the buffer discs 10 are thereby pulled from the chain. On version PROFI 20TI with chain box, three additional run-on elements are provided on the bottom block (see spare parts list).

**Assembly**

- ▶ Push the buffer assembly (buffer 9 plus buffer discs 10, edge encloses buffer) onto the chain. On version PROFI 20TI with chain box, a run-on element must be pushed onto the chain before pushing on the buffer assembly (see spare parts list for adjustment).
- ▶ Align the chain and fasten it to the assembly chain in the bottom block by means of the open chain link.
- ▶ Pull the chain through the bottom block and detach the assembly chain and the open chain link from the chain.
- ▶ Push the run-on element 8 onto the chain. On version PROFI 20TI with chain box, an additional run-on element must be pushed onto the chain (see spare parts list for adjustment).
- ▶ Align the chain and pull through the centre section by means of the assembly chain.
- ▶ Detach the assembly chain and the open chain link from the chain.
- ▶ Push the run-on element 7 onto the chain. On version PROFI 20TI with chain box, an additional run-on element must be pushed onto the chain (see spare parts list for adjustment).
- ▶ Align the chain and pull through the bottom block by means of the assembly chain.
- ▶ Detach the assembly chain and the open chain link from the chain.
- ▶ If no assembly chains have been used, the end of the chain must be inserted into both the bottom block and the centre section and pulled through by turning the deflection sprockets using an auxiliary tool.

- ▶ Align the chain and fasten the end chain link to the hoist body by means of the end chain link pin. (Position of the weld must align with that of the following links.)

**In the case of the PROFI 20 TI**

If the end chain link pin was pulled out completely, the bottom block chain link and the end chain link of the idle chain have to be aligned. (Position of the weld must align with that of the following links.)

- ▶ Drive in a new roll pin to secure the end link pin.

**REMOVING AND INSTALLING CLAMP AND BUFFER**

**Removal** (see illus. page 50)

- ▶ In the case of operation with chain box, run the chain out of the chain box and detach it from the hoist.

**Note:** In the case of hoists with chain box, the end chain link of the idle chain **4** is not attached to the hoist body.

- ▶ In the case of hoists without chain box, detach the chain link of the idle chain (for double chain and quadruple chain hoists, except for EH 20, also the end link of the bottom block chain **1**) from the chain mount on the hoist body. Drive out the roll pin **2** and remove the end chain link pin **3**.
- ▶ Immediately fasten the end link of the bottom block chain to the hoist body in order to prevent the chain from becoming twisted.
- ▶ Drive out the roll pin **9** from the clamp **10**.
- ▶ Remove the clamp from the chain.
- ▶ Detach the buffer **11** and buffer discs **12 + 13** from the chain. On version PROFI 20TI with chain box, it must be ensured that the three additional run-on elements remain on the chain (see spare parts list).

**Assembly**

In the case of operation with chain box:

- ▶ Push the buffer disc with edge (edge encloses buffer), buffer and buffer disc without edge onto the chain.
- ▶ Insert the tenth chain link into the chain pocket of the clamp (chain pocket away from hoist body, pointed outwards).

- ▶ Drive in a new roll pin to secure the chain link in the clamp.
- ▶ Attach the chain box.

In the case of operation without chain box:

- ▶ Align the chain link of the idle chain (for double chain and quadruple hoists, except for EH 20, also the end link of the bottom block chain) and fasten to the hoist body by means of the end chain link pin (position of the weld must align with that of the following links).
- ▶ Drive in a new roll pin to secure the end chain link pin.



**ATTENTION!**

Do not twist the chain! The chain is subjected to impermissible stresses if the chain is twisted.

**CHECKING CHAIN, CHAIN SPROCKET AND CHAIN GUIDES**

See also **Check dimensions**, page 55. If the chain of the JDN Air Hoist displays one of the following features, it must be replaced with a new one:

- ▶ Corrosion scars
- ▶ Bent or damaged chain links
- ▶ Chain drawn stiff
- ▶ Wear over 11 pitches ( $A_{max}$ )
- ▶ Single pitch wear ( $B_{max}$ )
- ▶ Elongation of a single link ( $D_{max}$ )

Check the entire length of the chain.

Please observe the information contained in DIN 685, part 5 when checking chains. For further instructions see ISO 7592.

**CHECK DIMENSION**

**HOIST CHAIN**

Note: When checking the replacement limit, future wear to the next checking date must be taken into account. If the chain dimension values are outside the limit values specified in the table when checked, the chain has reached its replacement limit and must be replaced by a new one. The chain sprockets must also be replaced together with the chain, as otherwise the new chain will be subjected to increased wear. Each chain re-placement must be documented in the inspection log.

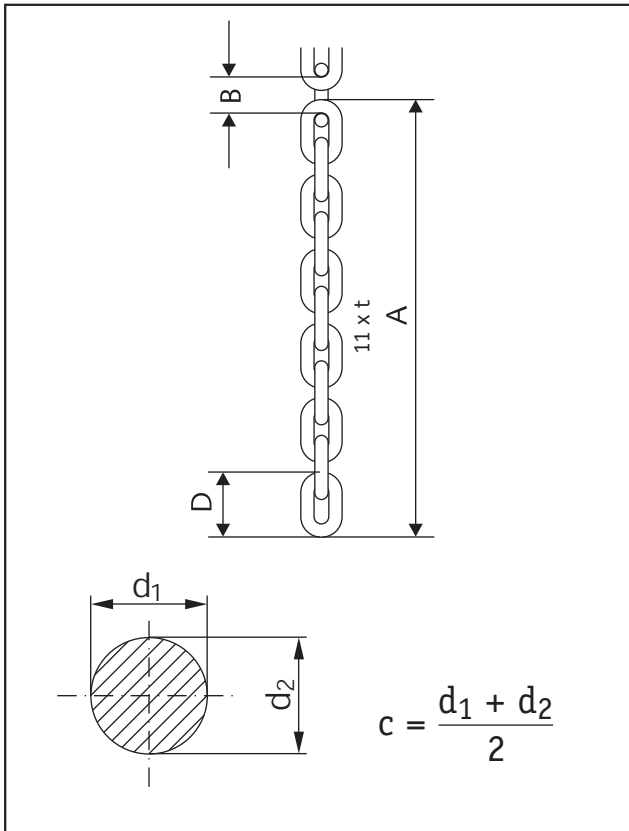

Check dimensions of hoist chain

Chain d x t	13 x 36	16 x 45
Dimension A max. 11 x t inside max.	429.2 404.3	536 505.3
Dimension B max.	37.9	47.4
Dimension C min.	11.7	14.4
Dimension D max.	63.9	79.3

Dimensions in mm

**LOAD HOOK**

If the hook opening  $a$  and the height  $h$  of the load hook are outside the wear limits, the hook must be replaced.

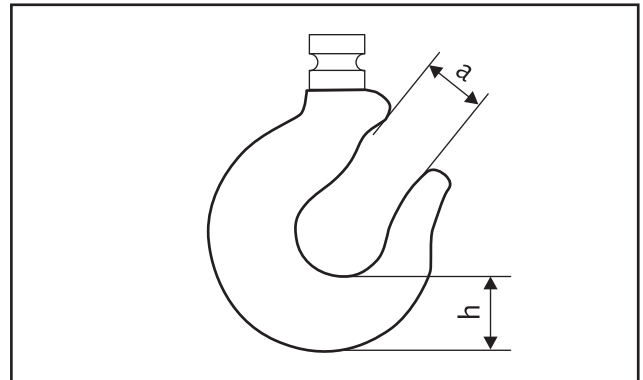

Check dimensions of the load hook

Type	Maximum permis. dimension of hook opening "a" <sup>1)</sup>	Minimum permis. dimension of height "h"
PROFI 3 TI	35.7	36.1
PROFI 6 TI	46.0	44.7
PROFI 10 TI, EH 10	50.4	58.9
PROFI 16 TI, EH 16	60.6	71.3
PROFI 20 TI, EH 20	83.4	80.8

Dimensions in mm

<sup>1)</sup> If a safety catch is fitted, the thickness of the safety catch must be subtracted from the maximum hook opening dimension  $a$ .

**WEAR DIMENSIONS FOR CHAIN SPROCKETS**

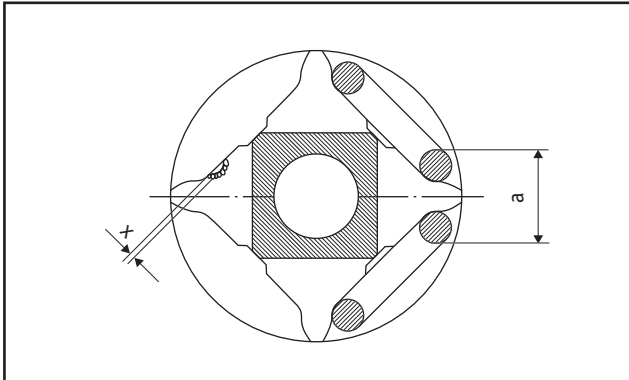

*Wear dimensions for chain sprockets*

Chain size d x t mm x mm	z (1)	a mm	x mm
13 x 36	4	32.8	0.25
16 x 45	4	38.5	0.30

**a, x** = limit dimensions after maximum permissible wear

**z** = number of teeth of the chain sprocket

**d x t** = nominal diameter times pitch of chain link

**WEAR DIMENSIONS FOR CHAIN GUIDES AND HOOK MOUNTS**

Check the chain guides for wear and when the following wear dimensions are reached with regard to chain guide diameters or hook mounts in the centre section of the device: Replace the housing:

Chain diameter	13	16
Wear dimension	1.4	1.7

Dimensions in mm

The wear dimension must be measured at the points on the guide surfaces which have been worn down by the chain.

**CHECKING AXIAL PLAY**

**Maintenance and lubrication**

Please ensure that load hooks and/or load eye mounts are regularly checked, at least once a year. **Especially important:** in areas where wear-promoting conditions such as high ambient temperatures or corrosive substances in the atmosphere are present, or where lubricants may be washed out, **the frequency of maintenance and inspection intervals must always be increased.**

**HAZARDS IN THE CASE OF INSUFFICIENT MAINTENANCE/LUBRICATION**



**DANGER!**

In the event of insufficient maintenance/lubrication the extent of wear may be so high that there is a danger of loads falling.

**PREVENTION OF DANGERS**

Dangers are avoided by regular maintenance/lubrication in suitable intervals.

**When the axial play of the installed hook or load eye exceeds the maximum play specified, the worn parts must be replaced.**



**CHECK DIMENSIONS FOR THE AXIAL PLAY**

Bottom block type	Axial play "x" max.
6.3 t, 10 t, 16 t	Max. 3.5 mm
20 t	Max. 11.5 mm

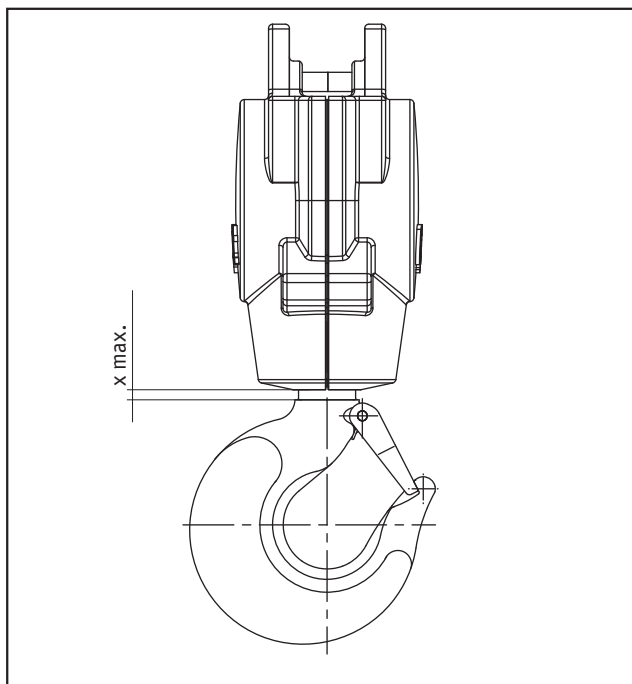

Bottom block with load hook or load eye

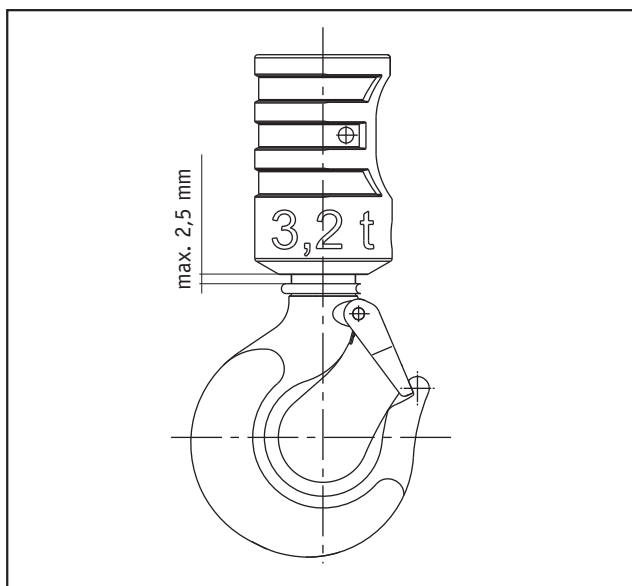

Load sleeve with load hook or load eye

**REMOVING AND INSTALLING CHAIN**



**ATTENTION!**

The chain supplied together with this JDN hoist is matched to the chain sprocket according to strict tolerances. In order to ensure optimum function of the chain and in order to prevent hazards, only genuine JDN chains must be installed.

**Note:** When a chain is replaced, the buffers must also be replaced. For information on changing buffers at the chain ends, see **Removing and installing load sleeve, bottom block, clamp and buffer section.**

Buffers and run-on elements not located on the chain ends are most easily replaced when the open chain link between the old and new chains passes the buffer to be replaced.



**ATTENTION!**

Do not twist the chain ends.

- ▶ In the case of operation with chain box: switch the hoist in the "lower" rotational direction and run the old chain out of the chain box. Then remove the chain box.
- ▶ Move the bottom block as close as possible to the hoist body and position it securely.
- ▶ In the case of hoists without chain box, detach the idle chain from the chain mount \_ for dual and quadruple chain hoists, the bottom block chain is released simultaneously – (see also **Removing and installing load sleeve, bottom block, clamp and buffer section**).
- ▶ Detach the clamp, buffer and buffer discs from the end of the idle chain. **For single chain hoists** also detach the load sleeve, buffer and buffer discs from the load chain. **For dual and quadruple chain hoists** with chain box, detach the bottom block from the hoist body. **For triple chain hoists**, detach the bottom block chain from the mount on the bottom block. (See also **Removing and installing load sleeve, bottom block, clamp and buffer section**.)
- ▶ Attach the new chain to the end link of the load section of the old chain after aligning the welds and the first chain link by means of an open chain link.

The welds on the upright chain links must face outwards when running over the chain sprockets. For this reason, the welds of the chain links which lie flat in the drive sprocket must face towards the gearbox in the case of treble and quadruple chain hoists. If the first link of the new chain is not correctly positioned, it must be removed.

**Note:** It is possible that the first chain link of the other chain end is correctly positioned. Switch the hoist to the "lift" rotational direction. The new chain will now run into the hoist while the

- ▶ old chain is simultaneously run out on the idle chain side.

Run the chain until the join between the old and new chain has run sufficiently (approx. 1 m) out of the centre section on the idle chain side.

- ▶ Detach the connection between the old and new chains.
- ▶ Install the clamp (at the 10th chain link), buffer and buffer discs on the idle chain section of the new chain.

Only in the case of operation without chain box, align the idle chain and attach to the fastening point on the hoist - for dual and quadruple chain hoists, except for EH 20, the bottom block chain is also attached here later. (See also **Removing and installing load sleeve, bottom block, clamp and buffer** section.)

- ▶ Attach the chain box if necessary.
- ▶ Switch the hoist in the "lift" rotational direction until the as yet free end of the **aligned** load chain is the correct length for attaching the chain link,
  - **for single chain hoists** in the load sleeve after the buffer and buffer discs have been pushed on,
  - **for dual and quadruple chain hoists** at the fastening point on the hoist body and
  - **for triple chain hoists** at the fastening point of the bottom block (see also **Removing and installing load sleeve, bottom block, clamp and buffer** section).

**Note:** If the chain link of the load chain is positioned incorrectly, it must be removed, the following chain link will be positioned correctly.

## REPLACING CHAIN AND CHAIN SPROCKET

**Note:** If the chain jams in the hoist and can no longer be run out, the gearbox must be dismantled. The gearbox retaining bolts must be removed for this purpose, and the end chain link pin must be pulled out. The chain wiper must then be removed. The gearbox can now be pulled approx. 15 mm from the centre section. In this position, the safety ring, item 440 (gearbox 3 TI/6 TI), item 500 (gearbox 10 TI/16 TI/20 TI/EH 10/EH 16/EH 20) (see E-list, gearbox) must be removed in the vicinity of one of the exhaust air guides. The gearbox housing can then be removed and the gearbox can be dismantled down to the sprocket wheel.

When removing the old chain, assembly chains **(1)** are brought into position on all the deflection sprockets by means of open chain links (see also **Removing and installing load sleeve, bottom block, clamp and buffer** section and section **Removing and installing chain** section).

Following replacement of the chain sprocket (see spare parts list) an assembly chain **(2)** is run carefully - with low air pressure - over the drive sprocket.

Fasten the new chain to the assembly chain on the drive sprocket by means of one or two open links **(3)** on the idle chain side. The first chain link **(4)** must run upright over the drive sprocket with the weld facing outwards. The welds of the chain links which lie flat in the drive sprocket **(5)** must face towards the gearbox in the case of treble and quadruple chain hoists. (See illustration.)

Switch the hoist to the "lower" rotational direction and detach the assembly chain from the chain after it comes out of the centre section.

Depending on the number of chains of hoist and after alignment, the new chain is pulled over the deflection sprocket of the bottom block and if necessary over the deflection sprocket of the centre section by means of further assembly chains.

**Note:** If the chain link on the idle chain side is positioned incorrectly, it must be removed, the following chain link will be positioned correctly.

Fastening of the chains and installation of the load sleeve, clamp, buffer and buffer discs is carried out in accordance with the **Removing and installing load sleeve, bottom block, clamp and buffer** section and the **Removing and installing chain** section.

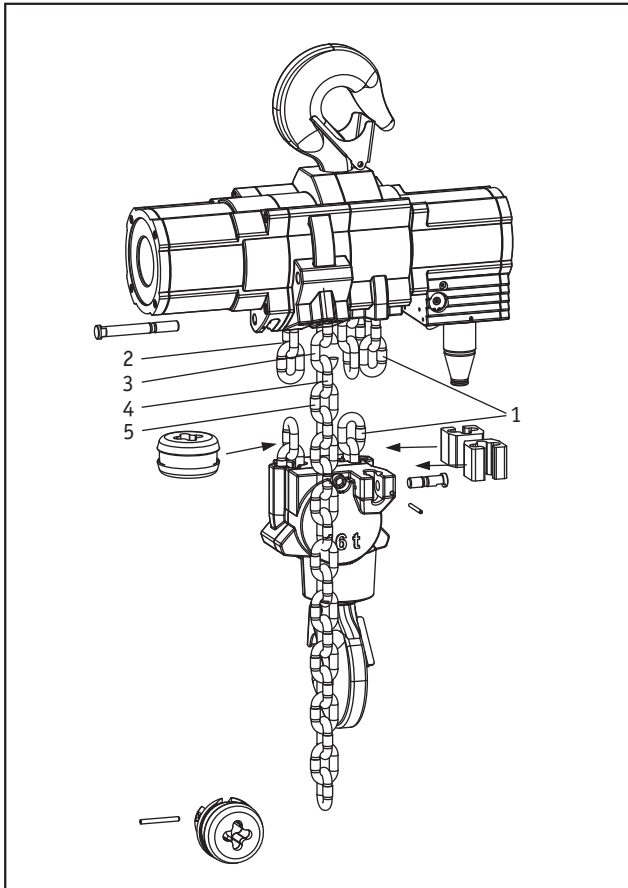

*Drawing in the chain*

## OVERLOAD PROTECTION

The PROFI 3 TI, 6 TI, 10 TI, 16 TI, 20 TI and EH 10, EH 16, EH 20 hoists are equipped with a new type of safety clutch as standard. This prevents loads exceeding the limit values set from being lifted. The limit value is set so that loads of 125% of the load carrying capacity cannot be lifted. 110% can be lifted in order to perform the dynamic overload test.



### ATTENTION!

The safety clutch must only be engaged for a short time in order to prevent unnecessary wear and overheating of the drive.

When the safety clutch is activated, the hoist should be unloaded by switching to a lowering movement.

The overload protection can also be activated when moving at full unloaded speed against a load to be lifted, even when it is below the load size set. We therefore recommend tensioning the slack chain before lifting the load.

### ADJUSTING OVERLOAD PROTECTION

The adjustment method described here is based on the attachment of test loads.



### DANGER!

If the overload protection is set too high, impermissibly high stresses may arise if a load exceeding the permissible load carrying capacity is attached.

- ▶ Unload the hoist
- ▶ Detach the gearbox cover (1) from the gearbox in order to gain access to the threaded pins (2) with lock nuts (3) located behind it.

### CORRECTING THE SET LIMIT VALUE

- ▶ Loosen the lock nuts. It must be ensured that the threaded pins **are not turned**.
- ▶ During each readjustment adjust the threaded pins to the same degree in order to adjust the disc springs evenly: turning clockwise - limit value is increased, turning anti-clockwise - limit value is reduced.
- ▶ Secure threaded pins with the lock nuts. Do not turn the threaded pins any more as the setting will be altered.
- ▶ Check the limit value for correct setting.
- ▶ Install the gearbox cover.

**RESETTING THE LIMIT VALUE**

- ▶ Loosen the lock nuts. Screw out the threaded pins - anti-clockwise - until the disc springs (4) are completely free of pre-tension.
- ▶ Then loosely screw in the threaded pins by hand - clockwise - to the stop, screw the lock nuts sufficiently far back beforehand.
- ▶ The limit value for reaching at least 110% of the load-carrying capacity is set at approx. 2 turns. Screw in the three threaded pins successively in small steps by approx. 1/2 turn. With this preadjustment after re-assembly, first let the safety clutch take effect for approx. 5 seconds (load hook on the upper end position with the motor running). Then let the load hook run for approx. 10 seconds without a load so that the outlet air cools the clutch down.
- ▶ Secure threaded pins with the lock nuts. Hold the threaded pins tightly in the process.
- ▶ Check the limit value for correct setting, correct if necessary.
- ▶ Install the gearbox cover.
- ▶ The adjusting and inspection result arrived at by qualified personnel must be entered in the lifting gear inspection log (limit value: see **Overload protection**, page 34).

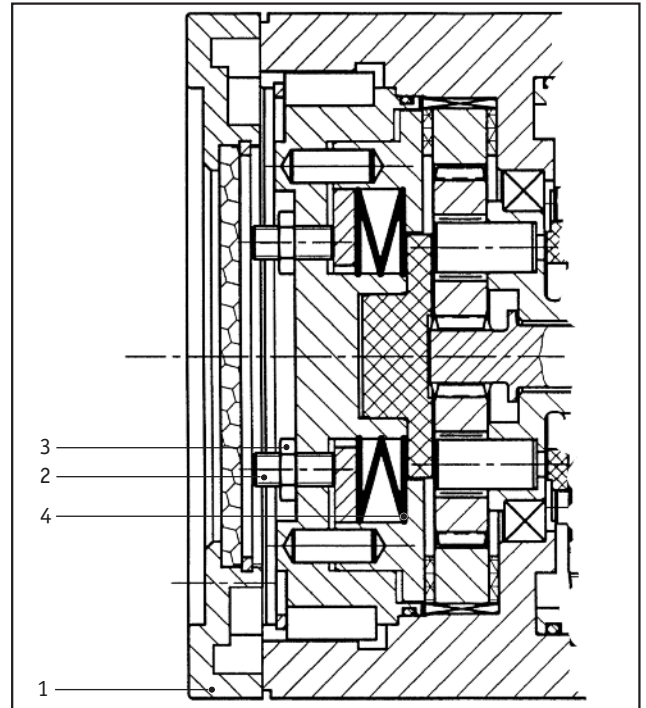

*Gearbox 3.2 t*

## FAULTS, CAUSE AND REMEDY

### FAULT TABLE

Fault	Possible cause	Remedy
Lifting not possible	Air pressure too low	Increase air pressure to the required value
	EMERGENCY STOP button is pressed	Release the EMERGENCY-OFF switch if the danger has been rectified
	Hand control is faulty	Have hand control repaired
Only very slow lifting possible	Brake does not release fully	Set air pressure to the relevant value, check seal of brake piston and change seal if necessary Check the adjustment of the brake piston (see <b>Spare Part List</b> )
	Brake lining worn or uneven	Replace brake lining
	Motor cover bolts loose	Tighten the bolts
	Air supply hoses leaking or loose	Check connections of air supply hose and control hoses and connect properly
	Cross section of air line too small	Use air line with sufficiently large cross section (check air pressure)
	Dirt in the service unit*, filter blocked	Clean service unit, ensure better air quality
	Silencer is clogged	Replace or clean silencer elements, improve air quality if necessary
	Motor vanes worn	Replace motor vanes
	Motor has run dry	Lubricate motor, check oiler*
	Control valve on motor	Have control valve repaired
	Safety clutch slips	Adjusting safety clutch
	Safety clutch slips due to chain wear	Replace chain with a new JDN Chain
Excessive running on during braking	Brake disc and/or brake piston worn	Replace brake disc and/ or brake piston
Loud chain noise on the chain sprocket	Chain dry	Lubricate chain
	Chain worn	Replace chain with a new JDN Chain
	Chain sprocket worn	Replace chain sprocket, check chain guide, replace if necessary
	Wrong chain drawn in	Identify chain and replace with JDN Chain if necessary
Lifting or lowering speed declines with high lifting heights or the motor comes to a standstill	Brake piston setting too tight	Correct adjustment of brake piston. At high ambient temperatures, perform adjustment with the device warmed up accordingly.

\*if installed

## ACCESSORIES

### FILTER SILENCER

With the use of a filter silencer, oil aerosols can be avoided and noise insulation improved:

- ▶ 99.9 % of oil aerosols during oil lubrication of the motor are absorbed by the filter element.
- ▶ The noise insulation reduces noise levels by 3 to 4 dB (A) compared with the standard silencer (sinter plate).

The ambient temperature must not be lower than - 10° C.

#### MAINTENANCE OF FILTER SILENCER

The filtered oil runs into the transparent collecting container **3**. This container must be emptied before the fluid level reaches the filter element.

- ▶ Turn the drain valve **4** 90° and allow the fluid to drain out.
- ▶ Close the drain valve.

The filter must be replaced after approx. 2500 hours of operation.

- ▶ Turn the collecting container **3** slightly and detach.
- ▶ Unscrew the filter element **2**.
- ▶ Insert a new filter element, with sealing ring **1** and push on collecting container until it engages.

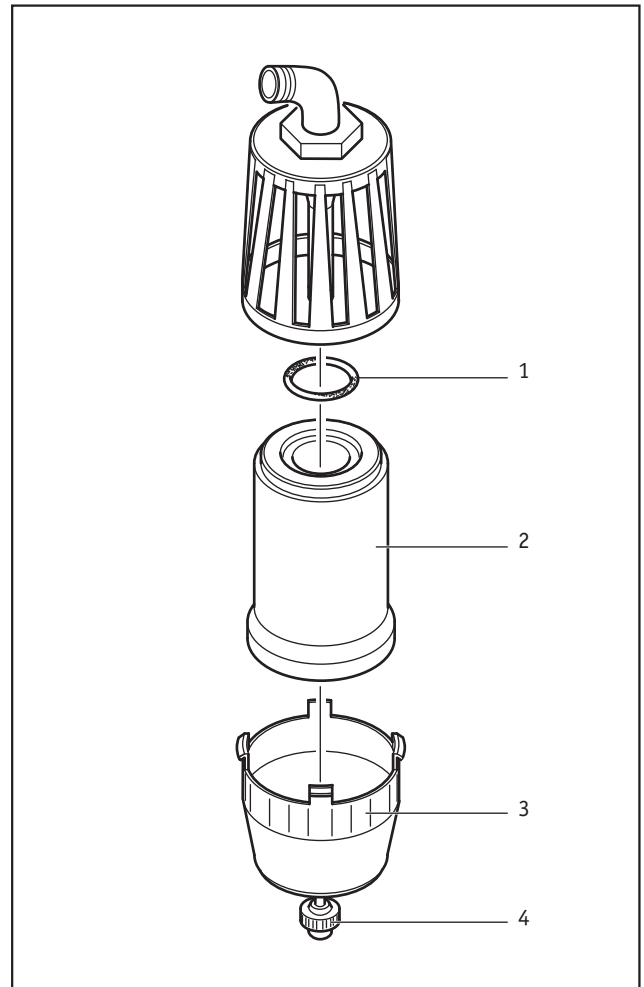

*Filter silencer*

### BOOSTER UNIT

In the event of a control hose length exceeding 10 m, the reaction times of the pushbutton controls increase significantly.

Consequently, a booster unit is generally installed on the motor for controls E, F and FI, enabling normal reaction times.

The operating temperature range is from 0° C to 80° C.

## CHAIN BOX

For various areas of application, a chain box enhances operational safety, i.e. when a chain which is hanging down could become caught up with the load.

JDN chain boxes are available in various sizes, corresponding to the chain lengths.



### ATTENTION!

Do not exceed the permissible filling capacity. Danger of chain dropping.



### ATTENTION!

Loads must not be moved against the chain box during lifting. If necessary, attach a clamp to the chain.

The clamp must be attached above the load hook so that it functions as a preliminary end stop. With the PROFI 6 TI and PROFI 10 TI (dual chain) the clamp must be positioned as far as necessary downwards on the reeved chain in order to support the bottom block (stationary chain). In addition, a spacer must be attached to the opposite (moving) chain above the buffer in order to relocate the load hook stroke limiter. Please contact us, if required. **For greater clarity, see the lower illustration on page 50.**

In all cases, a clamp is attached in the 10th chain link of the unloaded chain end so that a length of chain remains in the chain box when the bottom load hook position is reached. Thus, the chain cannot run next to the chain box during subsequent lifting (see section **Removing and installing chain** page 57).

Depending on the ratio of the size of the hoist (without running gear) and the chain box, the chain box may have to be stabilised by the customer due to an acceptable vertical hoist position. This is facilitated by a suspension point on the rear of the box. We will be happy to answer any questions on this matter.

Modifications may only be made to the chain box on agreement with J.D. Neuhaus GmbH & Co. KG.



### ATTENTION!

Never allow the chain to pile up in the chain box.

The chain must only enter the container via the chain drive. If it falls out of the container, e.g. during transportation, it must be run out completely on the load hook side and then run back into the container via the chain drive, in the air hoist operating position.

- ▶ After installing the chain box, lower the load hook to the bottom position once.
- ▶ Then activate the lifting movement and run the complete chain into the chain box.



### DANGER!

During operation with the chain box, lubrication of the chain is particularly important in order to prevent it from piling up and falling out.

Do not install longer chains when changing chains.

Furthermore, hazards arise due to rusty chains when operating with chain boxes, as the chain can form a heap and fall over the edge of the container rim. In addition, rusty chains are subject to extreme wear.

If the hoist has been transported with the chain in the chain box, the chain box must be emptied manually before initial operation (if necessary, remove the chain box from the hoist). The entire chain must then be allowed to run to the load side and, subsequently, be driven back into the chain box. The hoist must be kept in a hanging position during this procedure.

This process will ensure that the chain does not lock when loads are being lowered.

## APPENDIX

## TECHNICAL DATA

## JDN PROFI TI AIR HOISTS

Type		3 TI		6 TI		10 TI		16 TI		20 TI	
Air pressure	bar	4	6	4	6	4	6	4	6	4	6
Load-carrying capacity	t	3.2		6.3		10		16		20	
Number of chains		1		2		2		3		4	
Motor power	kW	1.8	3.5	1.8	3.5	1.8	3.5	1.8	3.5	1.8	3.5
Lifting speed at nominal load	m/min	2.5	5	1.2	2.5	0.8	1.6	0.5	1	0.4	0.7
Lifting speed without load	m/min	5	10	2.5	5	1.5	3.2	1	2	0.75	1.4
Lowering speed at nominal load	m/min	5.5	10.8	2.8	5.4	1.8	3.4	1.1	2.1	0.85	1.6
Air consumption at nominal load – lifting	m <sup>3</sup> /min	2.3	4.0	2.3	4.0	2.3	4.0	2.3	4.0	2.3	4.0
Air consumption at nominal load – lowering	m <sup>3</sup> /min	3.2	5.5	3.2	5.5	3.2	5.5	3.2	5.5	3.2	5.5
Air connection		G <sup>3</sup> / <sub>4</sub>		G <sup>3</sup> / <sub>4</sub>		G <sup>3</sup> / <sub>4</sub>		G <sup>3</sup> / <sub>4</sub>		G <sup>3</sup> / <sub>4</sub>	
Hose size (∅ inner/∅ outer )	mm	19/31		19/31		19/31		19/31		19/31	
Weight for standard lifting distance, rope control	kg	86		110		156		240		285	
Chain dimensions	mm	13 x 36		13 x 36		16 x 45		16 x 45		16 x 45	
Weight per 1 m chain	kg	3.8		3.8		5.8		5.8		5.8	
Standard lifting distance	m	3		3		3		3		3	
Control length for standard lifting distance	m	2		2		2		2		2	
Noise pressure level at nominal load <sup>1</sup> with standard silencer – lifting	dB (A)	76	78	76	78	76	78	76	78	76	78
Noise pressure level at nominal load <sup>1</sup> with standard silencer – lowering	dB (A)	78	80	78	80	78	80	78	80	78	80

<sup>1</sup> measured from 1 m distance according to DIN 45635 part 20



## DIMENSIONS

### JDN PROFI TI AIR HOISTS

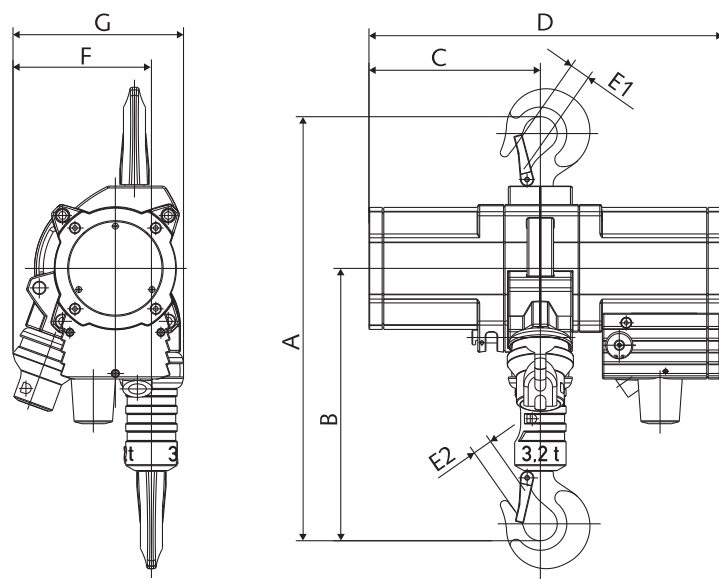

Type	3 TI	6 TI	10 TI	16 TI	20 TI
A* Minimum headroom	593	674	813	898	1040
B	373	454	548	598	667
C	233	233	308	382	382
D	483	483	575	692	692
E1	40	40	44	53	75
E2	30	40	44	53	75
F to centre of hook, without chain box	187	154	197	199	182
G maximum width	233	233	306	308	324

Dimensions in mm

\* Chain boxes increase the required headroom

**TECHNICAL DATA****JDN MONORAIL HOISTS**

Type		EH 10		EH 16		EH 20	
Air pressure	bar	4	6	4	6	4	6
Load-carrying capacity	t	10		16		20	
Number of chains		2		3		4	
Motor power, running gear	kw	0.3	0.7	0.3	0.7	0.3	0.7
Motor power, lifting gear	kw	1.8	3.5	1.8	3.5	1.8	3.5
Lifting speed at nominal load	m/min	0.8	1.6	0.5	1	0.4	0.7
Lifting speed without load	m/min	2	3.2	1.3	2	0.9	1.4
Lowering speed at nominal load	m/min	2.5	3.4	1.6	2.1	1.2	1.6
Travel speed at nominal load	m/min	10	12	10	12	10	12
Travel speed without load	m/min	10.5	13.5	10.5	13.5	10.5	13.5
Air consumption at nominal load, running gear	m <sup>3</sup> /min	1.0	1.3	1.0	1.3	1.0	1.3
Air consumption at nominal load, lifting gear(lifting)	m <sup>3</sup> /min	2.2	3.2	2.2	3.2	2.2	3.2
Air connection		G <sup>3</sup> / <sub>4</sub>		G <sup>3</sup> / <sub>4</sub>		G <sup>3</sup> / <sub>4</sub>	
Hose size (Ø inner/Ø outer)	mm	19/31		19/31		19/31	
Weight for standard lifting distance	kg	450		575		620	
Chain dimensions	mm	16 x 45		16 x 45		16 x 45	
Weight per 1 m chain	kg	5.8		5.8		5.8	
Standard lifting distance	m	3		3		3	
Control length for standard lifting distance	m	2		2		2	
Noise pressure level at nominal load <sup>1</sup> with standard silencer - lifting	dB (A)	75	78	75	78	75	78
Noise pressure level at nominal load <sup>1</sup> with standard silencer - lowering	dB (A)	81	80	81	80	81	80

<sup>1</sup> measured from 1 m distance according to DIN 45635 part 20

**DIMENSIONS**

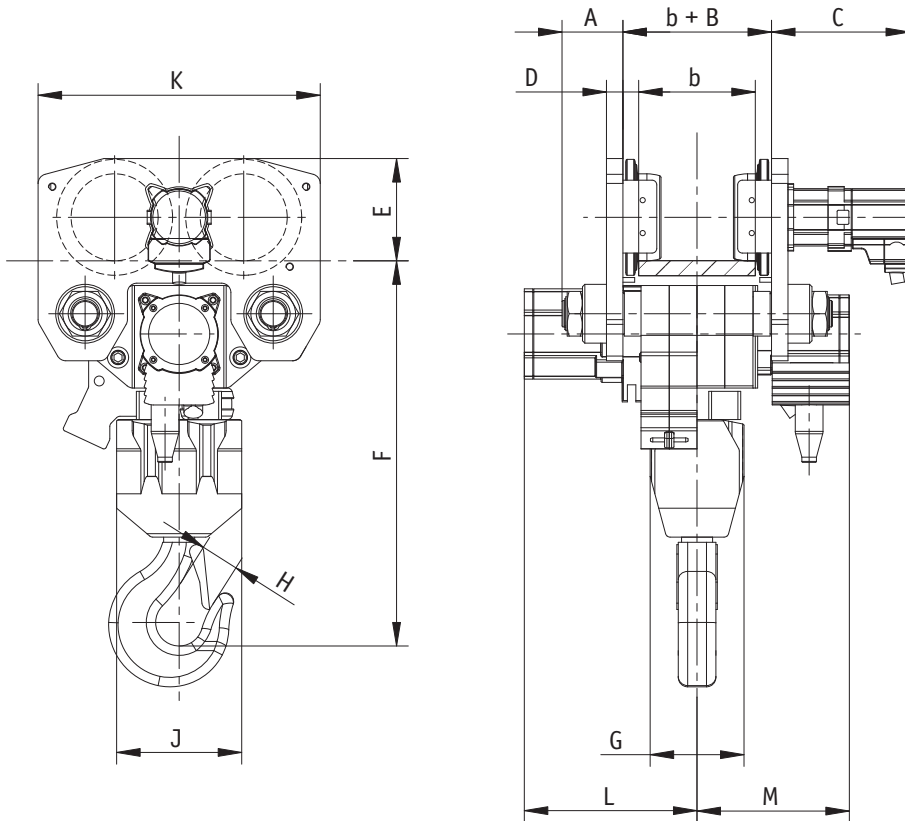

Type	EH 10	EH 16	EH 20
A	105	130	130
B	70	68	68
C	284	294	294
D	25	35	35
E	198	220	220
F*	705	750	820
G	138	213	202
H	44	53	75
J	192	185	266
K	580	600	600
L	308	367	367
M	266	325	325

Measurements in mm \* Chain boxes increase the required headroom

**AIR FLOW SHEETS**

**ROPE CONTROL, WITHOUT MAIN AIR EMERGENCY-STOP VALVE**

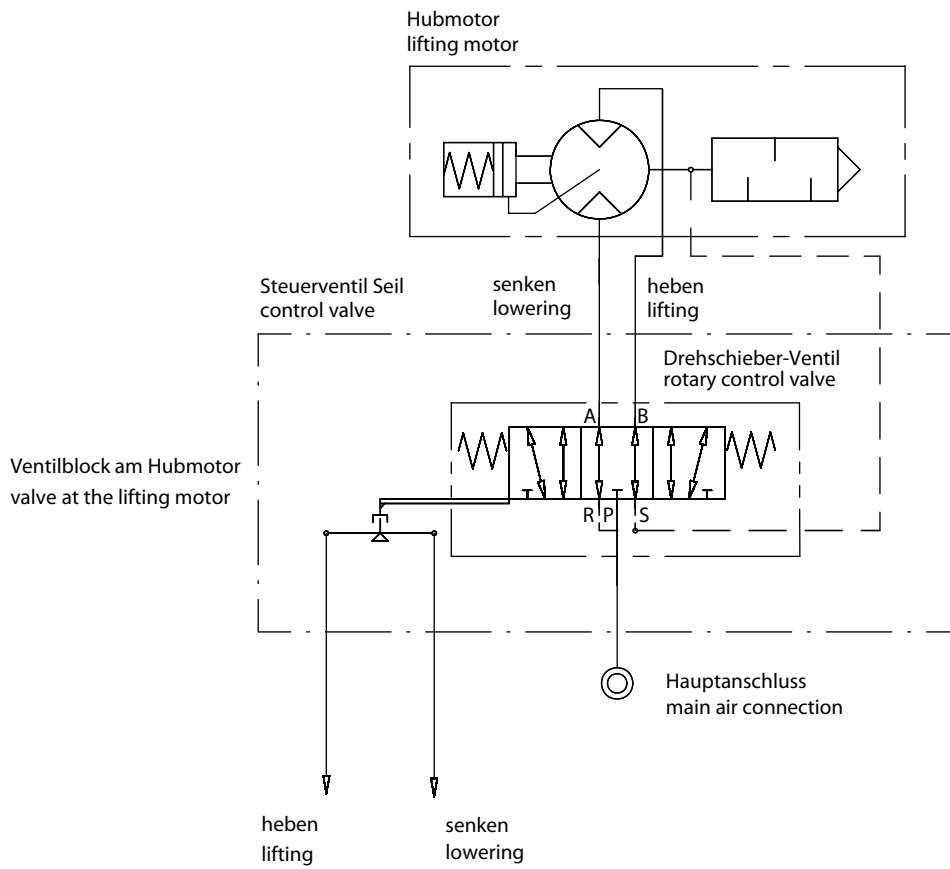

**E-CONTROL, 2-FOLD, WITH EMERGENCY STOP FUNCTION  
WITH MAIN AIR EMERGENCY-STOP VALVE**

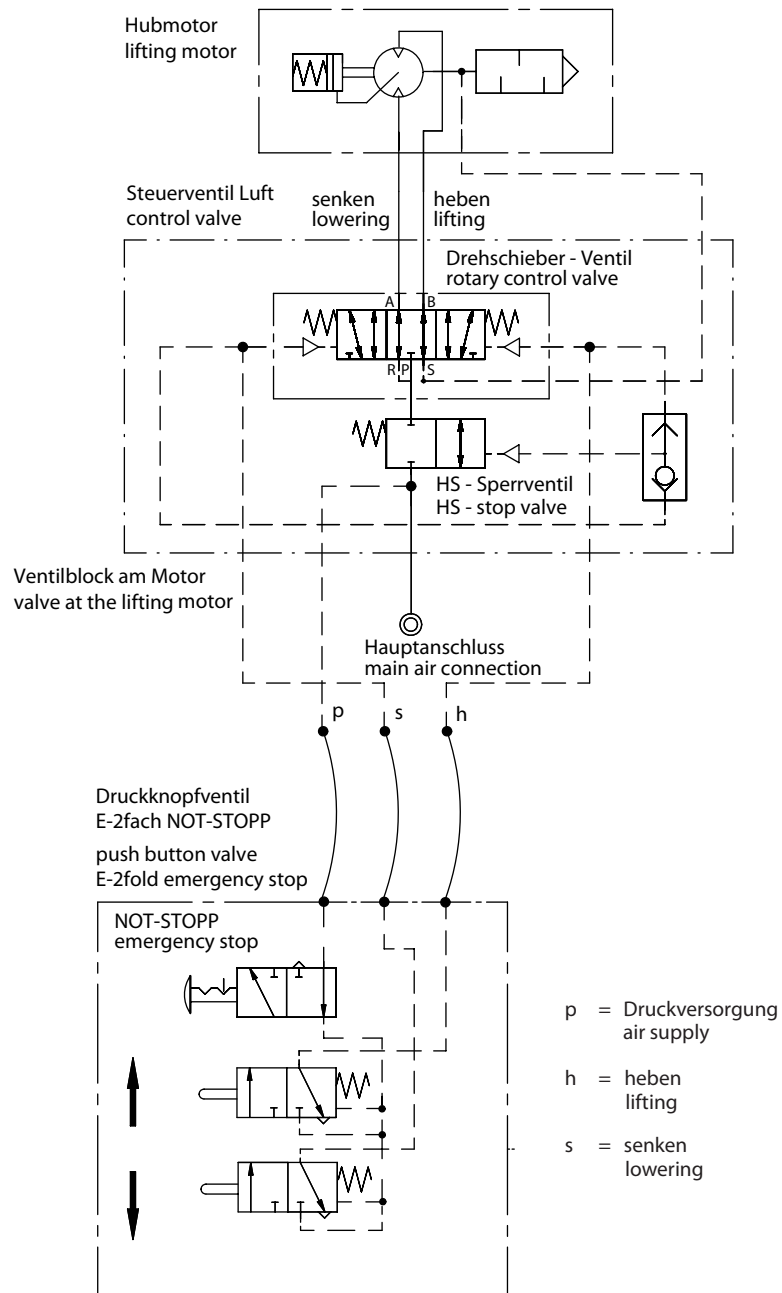

**E-CONTROL, 4-FOLD, WITHOUT EMERGENCY STOP FUNCTION  
WITHOUT MAIN AIR EMERGENCY-STOP VALVE  
(NOT FOR EWR)**

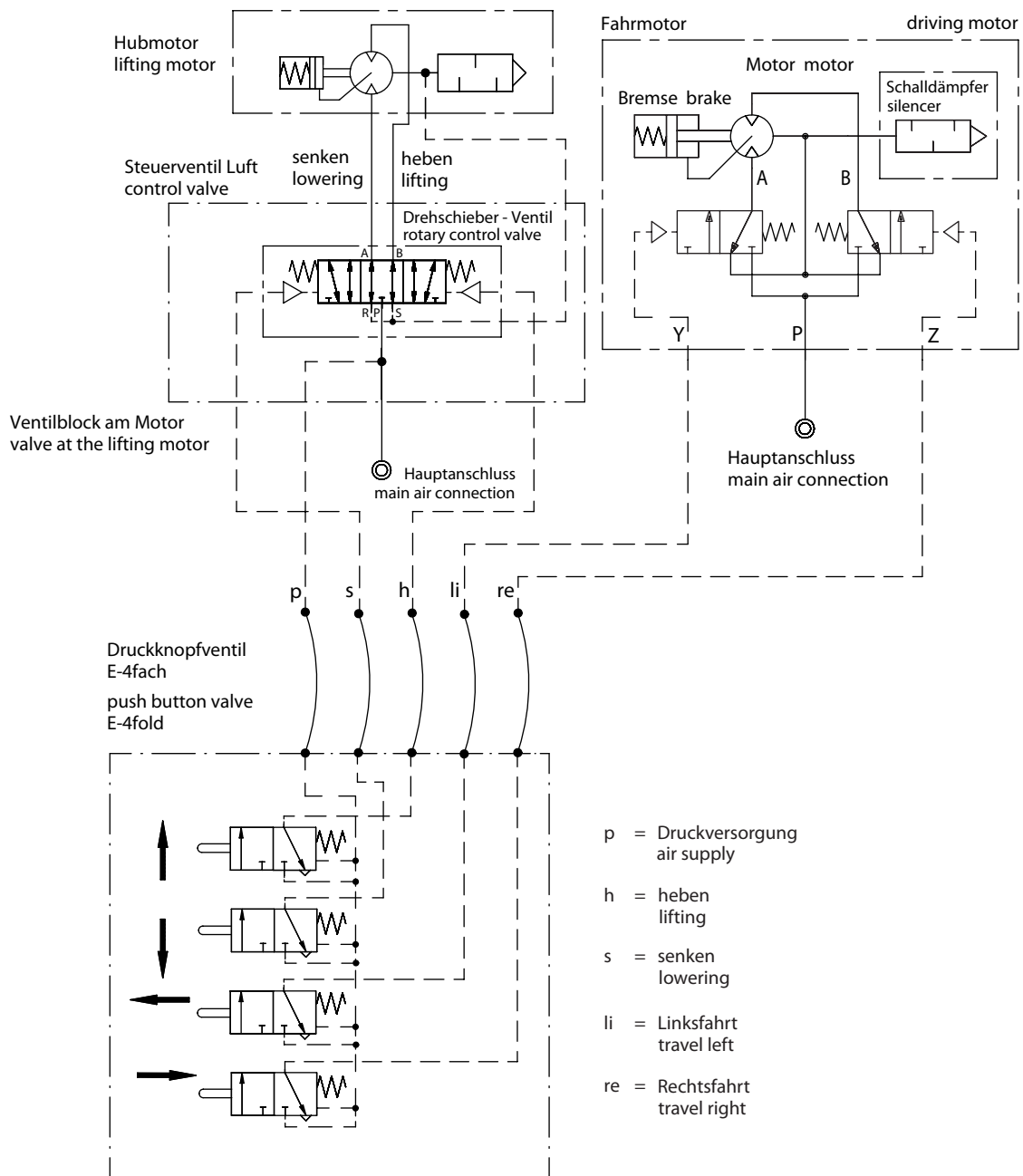

**E-CONTROL, 4-FOLD, WITH EMERGENCY STOP FUNCTION  
WITH EXTERNAL MAIN AIR EMERGENCY-STOP VALVE**

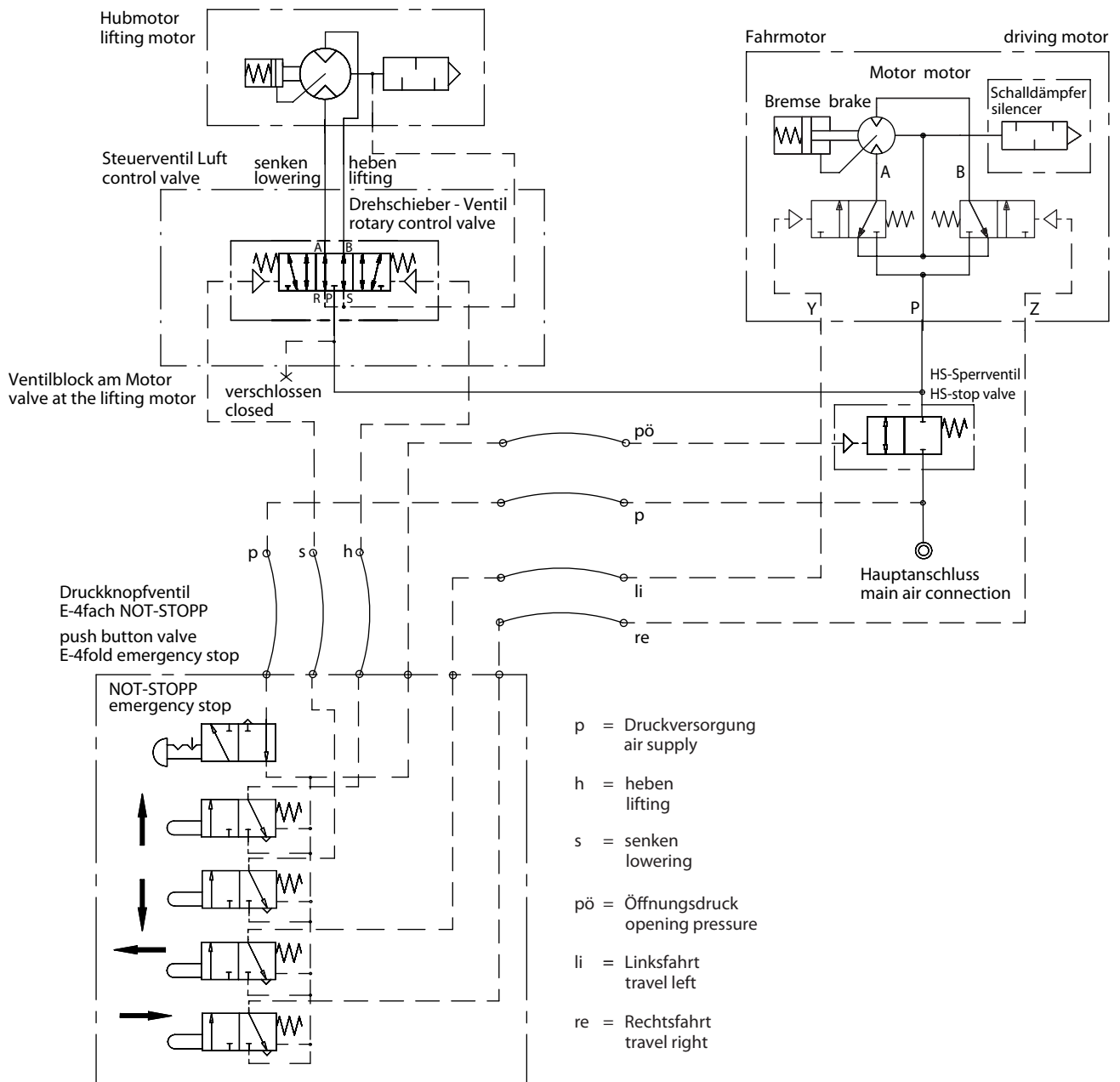

**FI-CONTROL, 2-FOLD, WITH EMERGENCY STOP FUNCTION  
WITH MAIN AIR EMERGENCY-STOP VALVE**

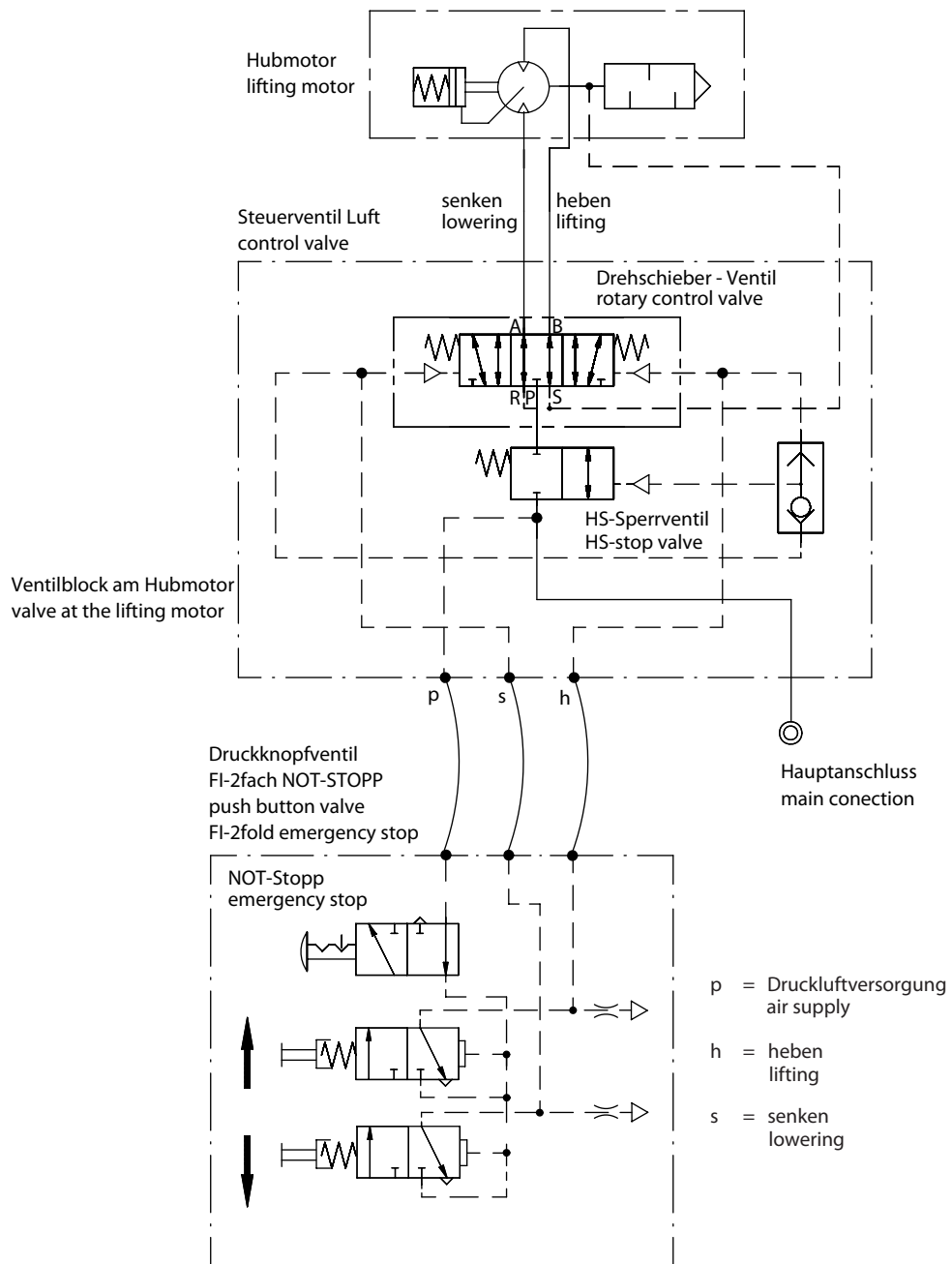



**F-CONTROL, 5-FOLD, WITH EMERGENCY STOP FUNCTION  
WITH MAIN AIR EMERGENCY-STOP VALVE**

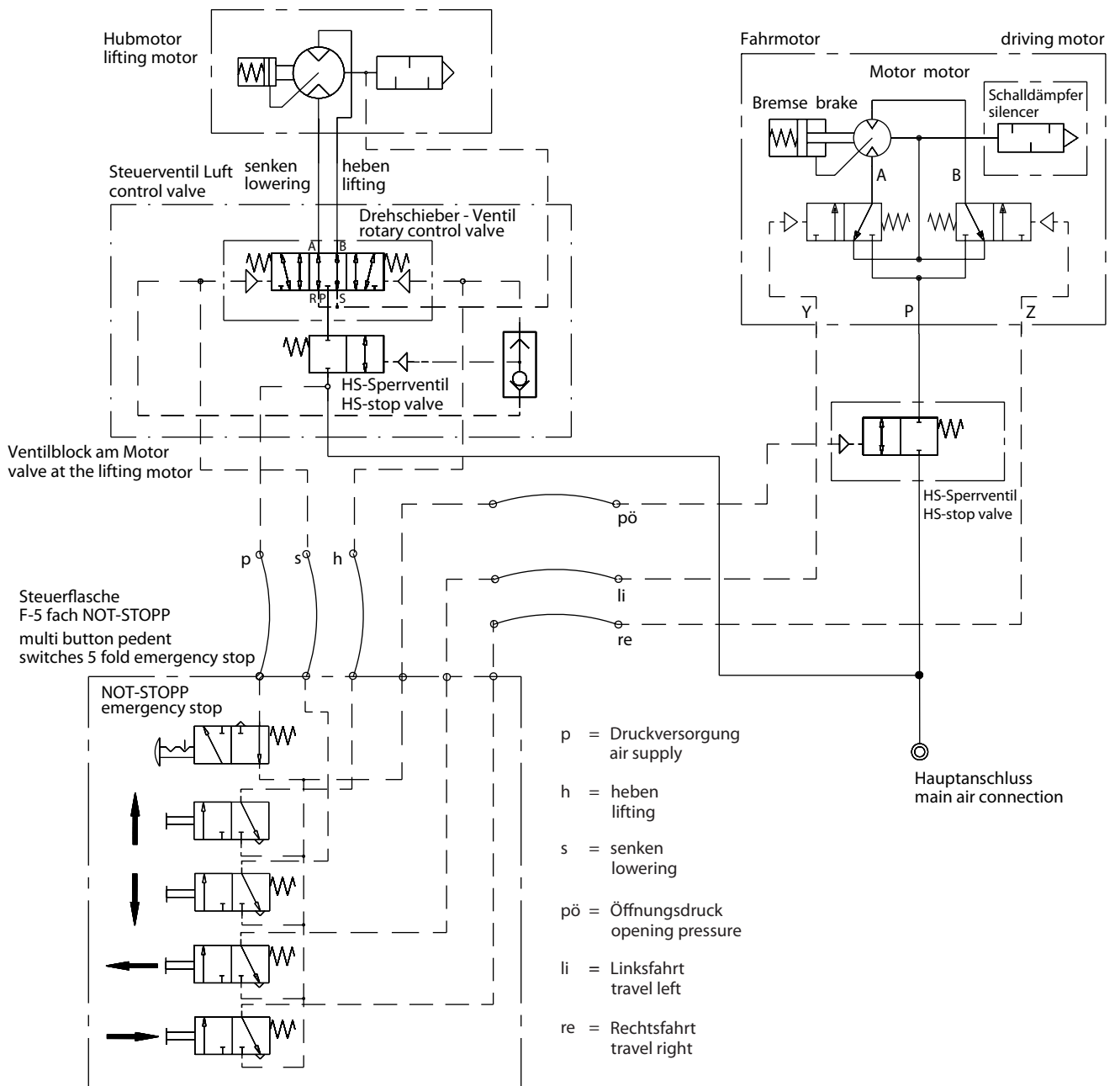

**F-CONTROL, 7-FOLD, WITH EMERGENCY STOP FUNCTION  
WITH MAIN AIR EMERGENCY-STOP VALVE**

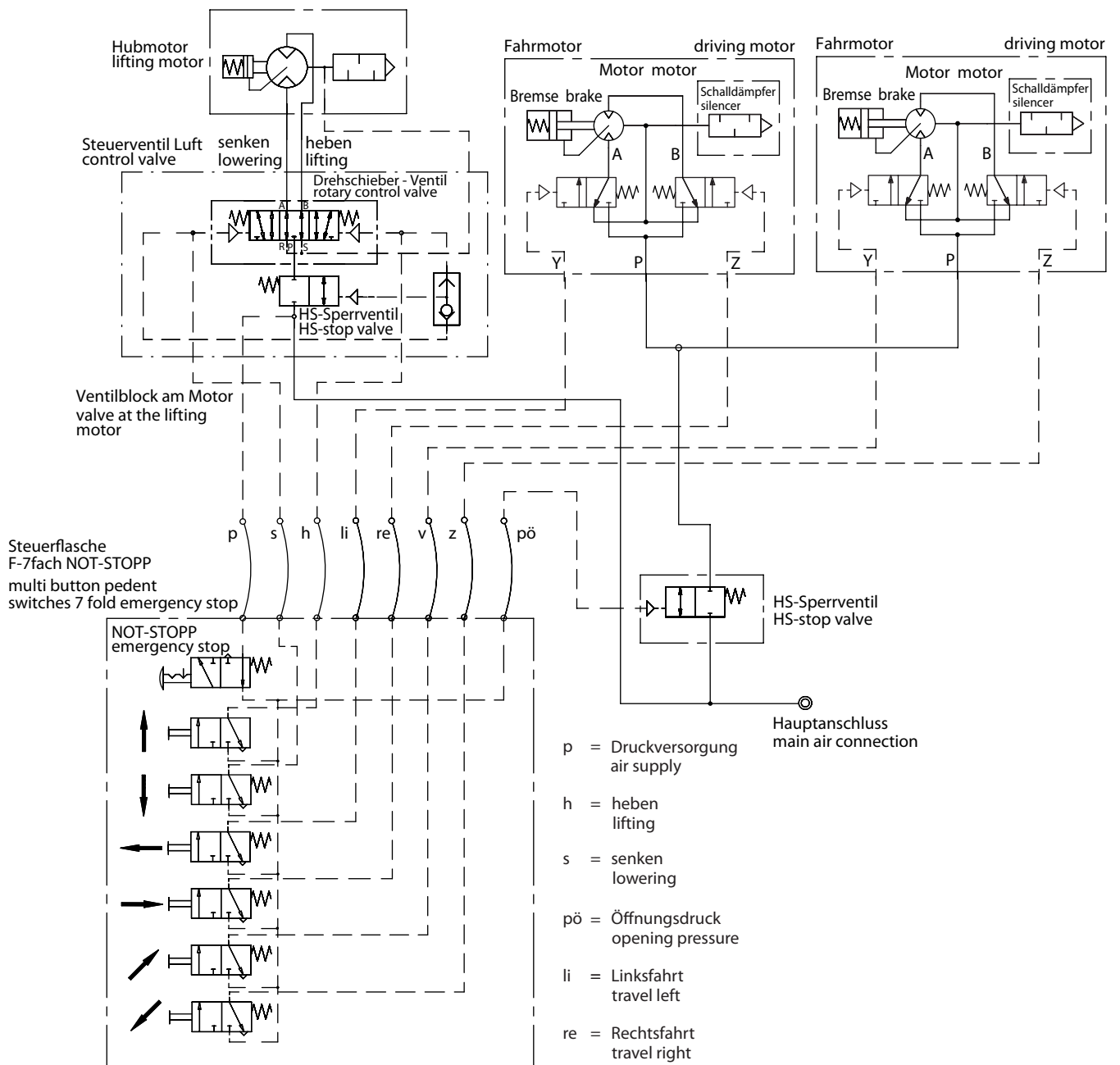



**PROFI TI** is a registered trademark of our company.  
**BA 816 GB** Subject to changes 072012

**J.D. Neuhaus GmbH & Co. KG** \_ D-58449 Witten-Heven  
Phone: +49 23 02 2 08-0 \_ Fax: +49 23 02 2 08-286  
[www.jdngroup.com](http://www.jdngroup.com) \_ [info@jdngroup.com](mailto:info@jdngroup.com)

